

Reference Manual

Ex Chek

NiMH Rechargeable Version

Combustible Gas Detector



biosystems

A Bacou-Dalloz Company

651 South Main Street
Middletown, CT 06457

(800) 711-6776 (860) 344-1079

Fax (860) 344-1068

Part number 13-123 Version 2.2

WARNING

EX CHEK PERSONAL PORTABLE GAS DETECTORS HAVE BEEN DESIGNED FOR THE DETECTION AND MEASUREMENT OF POTENTIALLY HAZARDOUS ATMOSPHERIC CONDITIONS

IN ORDER TO ASSURE THAT THE USER IS PROPERLY WARNED OF POTENTIALLY DANGEROUS ATMOSPHERIC CONDITIONS, IT IS ESSENTIAL THAT THE INSTRUCTIONS IN THIS REFERENCE MANUAL BE READ, FULLY UNDERSTOOD, AND FOLLOWED.

AVERTISSEMENT: LIRE ATTENTIVEMENT LES INSTRUCTIONS AVANT DE METTRE EN MARCHÉ.

**Ex Chek
Reference Manual
NiMH Version
Biosystems Part Number 13-123
Version 2.2
Copyright 2002
by
Biosystems
Middletown, Connecticut 06457**

All rights reserved.

No page or part of this operation manual may be reproduced in any form without written permission of the copyright owner shown above.

Biosystems reserves the right to correct typographical errors.

Table of Contents

Certifications	4
Signal Words	4
Warnings	5
Chapter 1. Ex Chek Description	7
1.1 Ex Chek capabilities	7
1.2 Methods of sampling.....	7
1.3 Combustible gas sensors	7
1.4 One Button Auto Calibration.....	8
1.5 Display backlight	8
1.6 Alarm logic.....	8
1.6.1 Atmospheric hazard alarms	8
1.6.2 Low battery alarms	9
1.7 Special microprocessor features	9
1.8 Classification for intrinsic safety	9
1.9 Options	9
1.9.1 Vibrator Alarm.....	9
1.9.2 Remote sample draw kit	9
1.9.3 Weather cover	10
1.10 Ex Chek design components	10
1.11 Ex Chek accessories	10
Chapter 2. Basic operation	11
2.1 Overview of Ex Chek operation	11
2.1.1 Operational warnings and cautions	11
2.1.2 Turning the Ex Chek on	12
2.1.3 Turning the Ex Chek off	12
2.1.4 Start-up sequence	12
2.2 Operating modes	12
2.2.1 Text Only mode	12
2.2.2 Technician mode	13
2.2.3 Changing operating modes.....	13
2.3 Ex Chek NiMH battery	13
2.3.1 Low battery voltage alarms.....	14
2.3.2 Battery charging procedure	14
2.4 Methods of sampling.....	14
2.4.1 Using the hand aspirated sample draw kit.....	14
2.5 Combustible gas sensor	15
2.5.1 Detection of missing or damaged Ex Chek sensor	15

Chapter 3. Calibration	15
3.1 Verification of accuracy	15
3.1.1 Effects of contaminants on combustible sensors.....	16
3.2 Fresh air "zero" calibration	17
3.3 Functional (bump) test.....	17
3.4 Auto-calibration	17
3.4.1 Fresh air "zero" auto-calibration sequence	18
3.4.2 "Span" calibration sequence.....	18
3.5 Manual calibration procedure	19
3.5.1 Fresh air "zero" through keypad buttons	19
3.5.2 Span calibration using keypad buttons.....	20
Chapter 4. Alarm settings	22
4.1 Alarm adjustment sequence	22
4.2 "Alarm Latch" command.....	22
4.3 Restoring the factory default alarm settings	23
Chapter 5. Ex Chek Advanced Functions	24
5.1 Advanced features overview.....	24
5.2 Re-setting the calibration gas concentration	24
5.3 Setting the security beep interval	24
Chapter 6. Trouble Shooting and Repair	25
6.1 Replacing Ex Chek sensor	25
6.2 Troubleshooting.....	25
6.3 Specific problems	26
6.3.1 Unit will not turn on	26
6.3.2 Unit will not turn off.....	26
6.3.3 Unstable sensor readings.....	26
6.3.4 Blank display	26
6.3.5 No audible alarm	26
6.3.6 Keypad buttons (+,-, Cal, Alarm) don't work	26
6.3.7 Can't make a "One Button" auto zero adjustment ("Too High" or "Too Low" for zero adjust) 26	26
6.4 Returning your Ex Chek to Biosystems for service or repair	27
Appendices	28
Appendix A: How to calibrate your Ex Chek in contaminated air	28
Appendix B: Biosystems Standard Warranty Gas Detection Products	29

Certifications

The Ex Chek is a personal, portable, microprocessor controlled, single sensor gas detector. The Ex Chek is designed to detect combustible gas.

The Ex Chek is Classified by Underwriters Laboratories, Inc. as to Intrinsic Safety for use in Hazardous Locations Class I, Division I, Groups A, B, C, and D, Class II Groups, E, F, & G, and the Canadian Standards Association for use in Hazardous Locations Class I Division I Groups A, B, C, and D. Classification for intrinsic safety is based on tests conducted in explosive gas / air (21 % Oxygen) mixtures only.

European Community (DEMKO Certificate number 99E.9933271X), EEx ia IIC T4 for instruments powered using DEMKO approved alkaline batteries.

The Ex Chek is also CE-Marked (Conformité Européenne). The UL, CSA, and DEMKO classifications marks indicate compliance with United States, Canadian, and European Community requirements.

Signal Words

The following signal words, as defined by ANSI Z535.4-1998, are used in the Ex Chek Reference Manual.

⚠ DANGER indicates an imminently hazardous situation which, if not avoided, will result in death or serious injury.

⚠ WARNING indicates a potentially hazardous situation which, if not avoided, could result in death or serious injury.

⚠ CAUTION indicates a potentially hazardous situation, which if not avoided, may result in moderate or minor injury.

CAUTION used without the safety alert symbol indicates a potentially hazardous situation which, if not avoided, may result in property damage.

Warnings

1. **⚠️WARNING** The Ex Chek personal, portable gas detector has been designed for the detection of combustible gas accumulations. An alarm condition indicates the presence of a potentially life-threatening hazard and should be taken very seriously.
2. **⚠️WARNING** In the event of an alarm condition it is important to follow established procedures. The safest course of action is to immediately leave the affected area, and to return only after further testing determines that the area is once again safe for entry. Failure to immediately leave the area may result in serious injury or death.
3. **⚠️WARNING** Use only (DEMKO approved) Duracell MN2400 or Eveready E92, size AAA, 1.5V Alkaline Batteries. Substitution of batteries may impair intrinsic safety.
4. **⚠️WARNING** The accuracy of Ex Chek instruments should be checked periodically with known concentration calibration gas. Failure to check accuracy can lead to inaccurate and potentially dangerous readings.
5. **⚠️WARNING** A sensor that cannot be calibrated or is found to be out of tolerance must be replaced immediately. An instrument that fails calibration may not be used until testing with known concentration test gas determines that accuracy has been restored, and the instrument is once again fit for use.
6. **⚠️WARNING** Do not reset the calibration gas concentration setpoints in the Ex Chek unless the concentrations of your calibration gas differ from the concentrations of the calibration gas that is normally supplied by Biosystems for use in calibrating the Ex Chek.
7. **⚠️WARNING** Use of non-standard calibration gas and/or calibration kit components when calibrating the Ex Chek can lead to dangerously inaccurate readings and may void the standard Biosystems warranty.
Biosystems offers calibration kits and long-lasting cylinders of test gas specifically developed for easy calibration. Customers are strongly urged to use only Biosystems calibration materials when calibrating the Ex Chek.
8. **⚠️WARNING** Substitution of components may impair intrinsic safety.
9. **⚠️WARNING** For safety reasons the Ex Chek must be operated by qualified personnel only. Read, understand and follow the directions set forth in this reference manual before operating the Ex Chek.
10. **⚠️WARNING** The Ex Chek has been tested for intrinsic safety in Explosive Gas/AIR(21.0% O₂) Only.

AVERTISSEMENT: LA SUBSTITUTION DE COMPOSANTS PEUT COMPROMETTRE LA SÉCURITÉ INTRINSÈQUE.

ATTENTION: POUR DES RAISONS DE SÉCURITÉ, CET ÉQUIPEMENT DOIT ÊTRE UTILISÉ, ENTRETENU ET RÉPARÉ UNIQUEMENT PAR UN PERSONNEL QUALIFIÉ. ÉTUDIER LE MANUEL D'INSTRUCTIONS EN ENTIER AVANT D'UTILISER, 'ENTREtenir OU DE RÉPARER L'ÉQUIPEMENT.

Chapter 1. Ex Chek

Description

1.1 Ex Chek capabilities

The Ex Chek is a single sensor gas detector designed to detect combustible gases and vapors. The Ex Chek includes numerous features designed to meet specific user requirements. This chapter will broadly discuss the use and capabilities of the Ex Chek.

1.2 Methods of sampling

The Ex Chek may be used in either diffusion or sample-draw mode. In either mode, the gas sample must enter the sensor compartment for the instrument to register a gas reading.

In diffusion mode, the atmosphere reaches the sensor by diffusing through the sensor port on the front of the instrument. Normal air movements are enough to carry the sample to the sensor. The sensor reacts quickly to changes in the concentration of the gas being measured.

It is also possible to use the Ex Chek to sample remote locations with the hand-aspirated sample-draw kit that is available separately. During remote sampling, the gas sample is drawn into the sensor compartment through the probe assembly and a length of tubing.

Use of the sample draw kit is covered in section 2.4.

1.3 Combustible gas sensors

As an environment becomes contaminated with combustible gases or vapors, concentrations can climb until they eventually reach ignitable or explosive levels. The minimum amount of a combustible gas or vapor in air that will explosively burn if a source of ignition is present is known as the Lower Explosive Limit (LEL) concentration. Ex Chek

combustible gas readings are given in percent LEL, with a range of zero to one-hundred percent explosive. The Ex Chek combustible gas sensor is non-specific and responds to all combustible gases and vapors.

Combustible sensors contain two coils of fine wire coated with a ceramic material to form beads. These two beads are strung onto the opposite arms of a balanced Wheatstone Bridge circuit. The "active" bead is additionally coated with a palladium based material that allows catalyzed combustion to occur on the surface of the bead. The palladium catalyst is not consumed in the combustion reaction, it simply enables it to occur. It is not necessary for the combustible vapor to be present in LEL concentrations in order for this reaction to occur. Even trace amounts of combustible gas present in the air surrounding the sensor will be catalytically burned on the surface of the bead.

The "reference" bead lacks the palladium outer coating but in other respects exactly resembles the active bead. A voltage is applied across the active and reference elements, causing them to heat. If combustible vapors are present, the active bead will be heated by the reaction to a higher temperature. The temperature of the untreated reference bead is unaffected by the presence of gas. The difference between the temperatures of the two beads will be proportional to the amount of combustible gas present.

Since the two beads are strung on the opposite arms of a Wheatstone Bridge electrical circuit, the difference in temperature between the beads is perceived by the instrument as a change in electrical resistance.

It is important to note that catalytic "hot bead" type combustible sensors require the presence of oxygen (at least 10 percent by volume) in order to detect accurately. A

combustible sensor located in a 100 percent pure combustible gas or vapor environment containing no oxygen will be unable to burn the combustible gas and will produce a reading of zero percent LEL.

1.4 One Button Auto Calibration

The Ex Chek detector has been designed for easy verification of accuracy. Biosystems' "One Button" calibration logic means that all normal day-to-day operating procedures, including automatic calibration adjustment, may be undertaken through the use of the single on/off MODE button.

⚠WARNING The accuracy of Ex Chek instruments should be checked periodically with known concentration calibration gas. Failure to check accuracy can lead to inaccurate and potentially dangerous readings.

Calibration is a two step procedure. In the first step the Ex Chek is taken to an area where the atmosphere is fresh and a "zero" adjustment is made by pressing the on/off MODE button. The second step of the calibration procedure is the sensor response or "span" adjustment. In this step the sensor is exposed to known concentration calibration gas. If the instrument recognizes a deviation from the expected response, it will automatically adjust itself so that the readings match the concentration of the gas being used.

Calibration procedures are discussed in detail in Chapter 3.

1.5 Display backlight

A manually activated display backlight allows the LCD to be read even in dim light conditions. Pressing the on/off MODE button once at any time during normal operation causes the backlight to be activated for 10 seconds. In the event of a gas alarm the backlight turns on

automatically and remains on until the alarm condition has cleared.

1.6 Alarm logic

Ex Chek alarms are user adjustable and may be set anywhere within the range of the sensor. When an alarm set point is exceeded a two-toned audible alarm sounds, a bright red LED alarm light flashes, and (if equipped) the optional vibrator type alarm is activated.

Ex Chek alarms are normally self-resetting. When readings drop back below the pre-set alarm levels, the instrument returns to normal operation, and the visual and audible alarms cease.

Ex Chek alarms can also be set to "latch" during an alarm condition. In the "latched" mode, once an alarm occurs both visual and audible alarms continue to sound even after the atmospheric hazard has cleared. The alarms must then be manually reset by pressing the MODE button.

Procedures for latching Ex Chek alarms are given in section 4.2.

1.6.1 Atmospheric hazard alarms

⚠WARNING The Ex Chek personal, portable gas detector has been designed for the detection of combustible gas accumulations. An alarm condition indicates the presence of a potentially life-threatening hazard and should be taken very seriously.

⚠WARNING In the event of an alarm condition it is important to follow established procedures. The safest course of action is to immediately leave the affected area, and to return only after further testing determines that the area is once again safe for entry. Failure to immediately leave the area may result in serious injury or death.

The ceiling alarm set point provided for Ex Chek detectors are set conservatively at the factory to maximize worker safety.

The procedures for adjusting alarm set points or restoring the factory default settings are given in section 4.1.

1.6.2 Low battery alarms

The rechargeable version of the EX Chek is equipped with a sealed rechargeable NiMH (nickel metal hydride) battery that is designed to provide up to 6 hours of continuous use.

When it is time to replace the batteries a "B" will appear in the lower left hand corner of the display screen, and the audible alarm will "beep" once per minute until the battery is replaced. Once the batteries are no longer able to provide adequate power to the instrument an audible chirping alarm will sound for 20 seconds and the display will toggle:

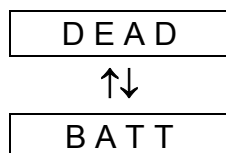

After 20 seconds, the instrument will shut itself off. The battery should be recharged as soon as possible after any low battery message is displayed.

Section 2.3.1 below covers battery charging procedures.

1.7 Special microprocessor features

Several automatic programs prevent tampering and misuse of the Ex Chek by unauthorized persons. Each time the detector is turned on, an electronic self-test is performed that assures the user of proper performance. The sensor, LED alarm light, and audible alarm are automatically evaluated, and the battery is monitored continuously for proper voltage.

The Ex Chek offers the following additional options that allow the user to customize the instrument for his/her own use.:

- security beep
- latching alarms
- calibration gas concentration settings
- alarm settings

Chapter 5 describes how to use these advanced technical features and setup choices in greater detail.

1.8 Classification for intrinsic safety

The Ex Chek is Classified by Underwriters Laboratories, Inc., as to Intrinsic Safety for use in Hazardous Locations Class I, Division I, Groups A, B, C, & D. and Class II Groups E, F, & G, the Canadian Standards Association for use in Class I, Groups A, B, C, and D, and the European Community (DEMKO Certificate number 99E.9933271X), EEx ia IIC T4 for instruments powered using DEMKO approved alkaline batteries.

Classification for intrinsic safety is based on tests conducted in explosive gas / air (21 % Oxygen) mixtures only.

1.9 Options

1.9.1 Vibrator Alarm

An optional internally mounted vibrator type alarm is available for use in high noise or other environments requiring additional warnings. The vibrator alarm option must be specified at the time the instrument is purchased.

1.9.2 Remote sample draw kit

An optional hand aspirated (squeeze bulb) sample draw kit is available for use in situations where the sample must be obtained from locations that are remote from the instrument. The sample draw kit consists of a sample draw adapter, squeeze

bulb, sample probe assembly, spare filters, and 10 feet of sample tubing.

1.9.3 Weather cover

An optional leather weather cover is available for use in environmentally harsh locations, or where additional protection is desired.

1.10 Ex Chek design components

- (1) **Case:** The instrument is enclosed in a durable, gasketed case constructed of a metal plated ABS / polycarbonate material.
- (2) **LCD display:** A top mounted liquid crystal display (LCD) displays readings, messages, and other information. A manually activated backlight ensures that the LCD may be easily read even in dim light conditions.
- (3) **Alarm light:** A bright red top-mounted LED (light emitting diode) alarm light visually warns users when an alarm level is exceeded.
- (4) **Audible alarm:** A loud two-toned audible alarm is provided to warn users of hazardous conditions.
- (5) **MODE button:** The on/off "Mode" button is used to turn the instrument on and off as well as control most other functions.
- (6) **Protective cap:** An o-ring sealed cap and moisture barrier filter protect the sensor from damage.
- (7) **Sensor:** The top-mounted sensor may be easily accessed for replacement or repair.
- (8) **Bottom surface:** The stainless steel belt clip may be removed to allow access to the 4 hidden push-buttons ("Cal," "Alarm," "+," and "-") used to control advanced functions.

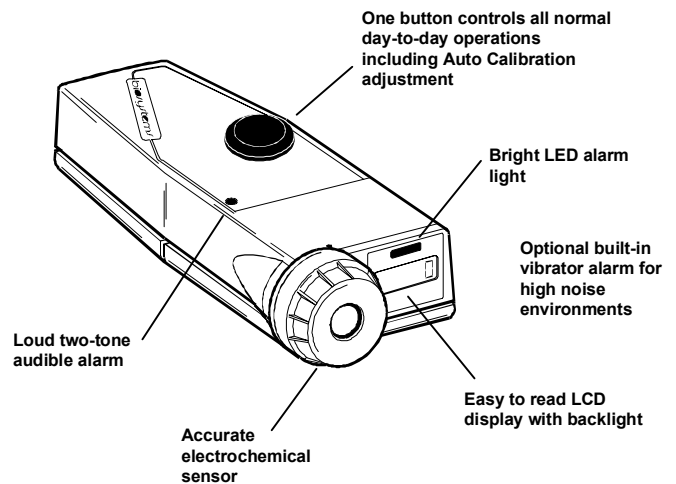

Figure 1.3: Ex Chek external features

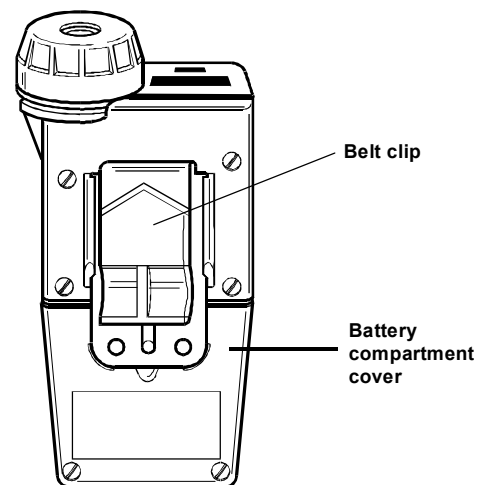

Figure 1.4: Ex Chek bottom surface

1.11 Ex Chek accessories

Ex Chek detectors are shipped complete with sensor, set of three AAA alkaline batteries (installed), calibration adapter, owner's manual and quick reference card. Optional Ex Chek accessories include sample draw kit, weather cover and internally mounted vibrator alarm (vibrator option must be specified at time of purchase).

Chapter 2. Basic operation

2.1 Overview of Ex Chek operation

The Ex Chek offers a choice of two modes of operation, "Text Only," and "Technician". Mode selection should be based on how much information is required, the skill level of the user, and the nature of the job.

2.1.1 Operational warnings and cautions

1. **⚠WARNING** The Ex Chek personal, portable gas detector has been designed for the detection of combustible gas accumulations. An alarm condition indicates the presence of a potentially life-threatening hazard and should be taken very seriously.
2. **⚠WARNING** In the event of an alarm condition it is important to follow established procedures. The safest course of action is to immediately leave the affected area, and to return only after further testing determines that the area is once again safe for entry. Failure to immediately leave the area may result in serious injury or death.
3. **⚠WARNING** Use only (DEMKO approved) Duracell MN2400 or Eveready E92, size AAA, 1.5V Alkaline Batteries. Substitution of batteries may impair intrinsic safety.
4. **⚠WARNING** The accuracy of Ex Chek instruments should be checked periodically with known concentration calibration gas. Failure to check accuracy can lead to inaccurate and potentially dangerous readings.
5. **⚠WARNING** A sensor that cannot be calibrated or is found to be out of tolerance must be replaced immediately. An instrument that fails calibration may not be used until testing with known concentration test gas determines that accuracy has been restored, and the instrument is once again fit for use.
6. **⚠WARNING** Do not reset the calibration gas concentration setpoints in the Ex Chek unless the concentrations of your calibration gas differ from the concentrations of the calibration gas that is normally supplied by Biosystems for use in calibrating the Ex Chek.
7. **⚠WARNING** Use of non-standard calibration gas and/or calibration kit components when calibrating the Ex Chek can lead to dangerously inaccurate readings and may void the standard Biosystems warranty.

Biosystems offers calibration kits and long-lasting cylinders of test gas specifically developed for easy calibration. Customers are strongly urged to use only Biosystems calibration materials when calibrating the Ex Chek.
8. **⚠WARNING** Substitution of components may impair intrinsic safety.
9. **⚠WARNING** For safety reasons the Ex Chek must be operated by qualified personnel only. Read, understand and follow the directions set forth in this reference manual before operating the Ex Chek.
10. **⚠WARNING** The Ex Chek has been tested for intrinsic safety in Explosive Gas/AIR(21.0% O₂) Only.

2.1.2 Turning the Ex Chek on

The black switch on the front of the Ex Chek is called the "MODE" button and is used to turn the Ex Chek on and off, and to control routine instrument operations. Press and hold the MODE button for one second to turn the Ex Chek on.

2.1.3 Turning the Ex Chek off

To turn the Ex Chek off press and hold the MODE button down for 3 seconds.

2.1.4 Start-up sequence

After the detector has been turned on, it will automatically go through an electronic self test and start up sequence that takes approximately twenty seconds.

During the self test sequence the LCD backlight will be activated, the visual LED alarm light will flash and the audible alarm will sound. If the instrument is equipped with the optional vibrator alarm it will briefly activate. During start-up the LCD display will also show several messages or "screens" in sequence.

The first screen displays the software version number:

CP 1.2

Note: The software version installed may differ from that shown above.

The second shows the type of sensor installed:

EX

Additional screens will briefly appear indicating the current peak alarm set point. If the Ex Chek is operating in the **Technician** mode, it will display the following factory installed (default) alarm set point.

PEAK
↓
ALRM
↓

10

This screen is followed by the current gas readings screen for the gas being measured, which alternates with a screen that identifies the type of gas being measured:

EX
↑↓
0

Note: The alarm set-point screens are omitted when the instrument is turned on while in the "Text Only" mode.

2.2 Operating modes

The Ex Chek has two operating modes. Operating mode selection determines the amount of information that will be displayed during routine operation.

2.2.1 Text Only mode

The simplest mode of operation is the "Text Only" mode. In this mode, during normal operation the LCD screen does not display numerical readings, only the indication "OK". This screen alternates with a screen that identifies the type of gas being measured:

EX
↑↓
OK

An alarm condition occurs when the sensor readings exceed the pre-set alarm level. During an alarm the indication changes from "OK" to the numerical value, the LED alarm light flashes, the audible alarm sounds, and (if equipped) the optional vibrator alarm is activated.

EX
↑↓
18

Ex Chek alarms are normally self-resetting. When readings drop back below the pre-set

alarm levels, the screen reverts back to the "OK" indication and visual and audible alarms cease.

2.2.2 Technician mode

The "**Technician**" mode of operation gives the user access to the numerical current gas readings screen regardless of alarm state and also gives access to the peak readings screen.

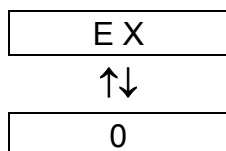

An alarm condition occurs when the sensor readings exceed the pre-set alarm level. During an alarm the numerical readings will indicate the current gas reading in terms of percentage of LEL, the LED alarm light flashes, the audible alarm sounds, and (if equipped) the optional vibrator alarm is activated.

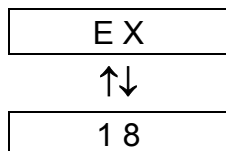

Ex Chek alarms are normally self-resetting. When readings drop back below the pre-set alarm levels, visual and audible alarms cease, and normal operation of the instrument resumes.

Pressing the MODE button in "**Technician**" mode allows the user to toggle between the peak readings screen and the current gas reading screen.

The first screen is the gas level display discussed above. Pressing the MODE button once displays the peak reading of the gas being measured since the instrument was switched on.

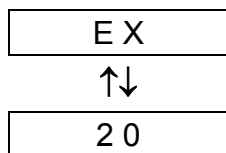

Pressing the MODE button again returns the display to the first screen showing current gas levels.

Regardless of mode selection, anytime the Ex Chek is in use it remembers the peak readings of the gas being measured and will go into alarm whenever appropriate.

2.2.3 Changing operating modes

It is possible to shift from one operating mode to another while the instrument is in use without turning the instrument off or resetting the peak alarms. Simply remove the belt clip on the bottom of the instrument to expose the four mini-push-buttons, and simultaneously press and hold the "+" and "-" buttons until the word "MODE" is displayed. Each time the operating mode is changed the display screen will briefly indicate the operating mode that has been selected.

Note: Shifting modes or otherwise reprogramming the instrument should only be done by employees who are authorized to do so.

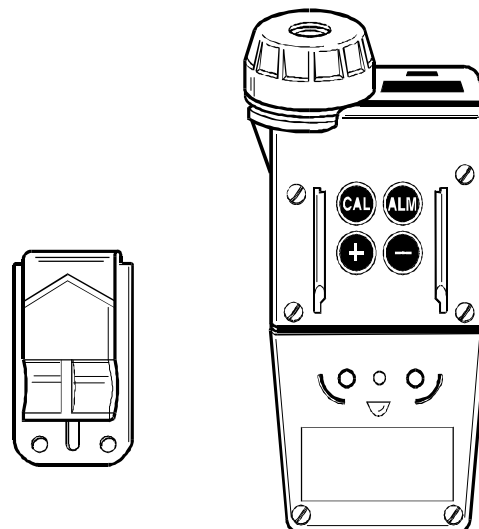

Figure 2.2. Ex Chek with belt clip removed exposing the four keypad pushbuttons

2.3 Ex Chek NiMH battery

Ex Chek detectors equipped with the rechargeable NiMH (nickel metal hydride)

battery are designed to provide up to 6 hours of continuous use. The NiMH battery is sealed in the Ex Chek and should not be disassembled in the field.

2.3.1 Low battery voltage alarms

When it is time to recharge the batteries a "B" will appear in the lower left hand corner of the display screen, and the audible alarm will "beep" once per minute until the batteries are replaced. Once the "B" is displayed, the user should have approximately 10 minutes of useful battery life remaining.

2.3.2 Battery charging procedure

⚠WARNING The Ex Chek must be located in a non-hazardous location during the charging cycle. Charging the Ex Chek in a hazardous location may impair intrinsic safety.

- (1) Check that the instrument is turned off. (If it is not, press the mode button until the message "Release button".)
- (2) Connect the charger cradle to the 110 VAC "wall cube" power source.
- (3) Plug the "wall cube" in and check to see that the "PWR" (power-on) indicator LED on the charger cradle is lit.
- (4) Slip the Ex Chek into the charger cradle and check to see that the "FAST" (fast charger) indicator LED on the charger cradle is lit.

Note: The "FAST" indicator will initially light up and remain lit for the first 15 minutes no matter what the battery pack voltage.

- (5) When charging is complete the "FAST" indicator will turn off. Charging is complete any time after the "TRIC" (trickle charge) indicator is lit.

Accuracy of the Ex Chek detector must be verified by exposure to known concentration test gas before the instrument is put back into service.

CAUTION To achieve optimal charge and ensure long battery life of the NiMH battery, make sure that charging takes place in an area where the ambient air temperature is between 40 and 86 degrees Fahrenheit (5 and 30 degrees Celsius). Charging the battery in temperatures above or below this range can damage the battery and will drastically affect battery life.

2.4 Methods of sampling

The Ex Chek may be used in either diffusion or sample-draw mode. In either mode, the gas sample must enter the sensor compartment for the instrument to register a gas reading.

In diffusion mode, the atmosphere reaches the sensor by diffusing through the sensor port on the front of the instrument. Normal air movements are enough to carry the sample to the sensor. The sensor reacts quickly to changes in the concentration of the gas being measured.

It is also possible to use the Ex Chek to sample remote locations with the hand-aspirated sample-draw kit that is available separately. During remote sampling, the gas sample is drawn into the sensor compartment through the probe assembly and a length of tubing.

2.4.1 Using the hand aspirated sample draw kit

- (1) Connect the slip-on sample draw cup with the squeeze bulb and hose assembly. (Connect the end of the short length of hose closest to the bulb to the sample draw cup. Connect the other end of the hose to the sample probe.)
- (2) Cover the end of the sample draw probe assembly with a finger, and squeeze the aspirator bulb. If there are no leaks in the sample draw kit components, the bulb should stay deflated for a few seconds.

- (3) Insert the end of the sample probe into the location to be sampled.
- (4) Squeeze the aspirator bulb several times to draw air from the remote location to the sensor compartment. Allow one squeeze of the bulb for every one foot of sampling hose for the sample to begin reaching the sensor compartment. Once the sample has reached the sensor, continue to squeeze the bulb at a rate of once per second for another full minute until readings stabilize.

Caution: Hand aspirated remote sampling only provides continuous gas readings as long as the bulb is being squeezed.

2.5 Combustible gas sensor

The Ex Chek contains a single combustible gas sensor.

It is important to note that catalytic "hot bead" type combustible sensors require the presence of oxygen (at least 10 percent by volume) in order to detect accurately. A combustible sensor located in a 100 percent pure combustible gas or vapor environment containing no oxygen will be unable to burn the combustible gas and will produce a reading of zero percent LEL.

For a detailed discussion of the theory behind the Ex Chek combustible sensor, see section 1.3 above.

2.5.1 Detection of missing or damaged Ex Chek sensor

If the Ex Chek sensor has been inadvertently removed or has sustained internal damage the Ex Chek will sound an audible alarm and flash the visible alarm LED while displaying "F L T" on the LCD display. The Ex Chek will stay in alarm mode until the unit is shut off and an operational sensor is installed.

Chapter 3. Calibration

The Ex Chek detector has been designed for easy calibration. The on / off "MODE" button is used to enter "Auto-Calibration" mode, and to automatically make all calibration adjustments.

It is also possible to manually calibrate the instrument by using simple push-button controls located on the instrument keypad.

"One-Button Auto-Cal" procedures are discussed in Section 3.4. Manual calibration procedures are discussed in Section 3.5.

3.1 Verification of accuracy

⚠WARNING The accuracy of Ex Chek instruments should be checked periodically with known concentration calibration gas. Failure to check accuracy can lead to inaccurate and potentially dangerous readings.

Verification of accuracy is a two step procedure. In the first step the Ex Chek is taken to an area where the atmosphere is fresh and the readings are checked. If the readings differ from those expected in fresh air a "zero" adjustment must be made. The second step is to make sure the sensor is accurate by exposing it to known concentration test gas and noting the response. LEL readings are considered accurate when they are within $\pm 10\%$ of the expected concentration as given on the calibration gas cylinder. If readings are accurate, there is no need to adjust your gas detector. If the readings are inaccurate, the instrument must be span calibrated before further use.

⚠WARNING Always check the expiration date on calibration gas cylinder(s) prior to use. Expired calibration gas can lead to inaccurate and potentially dangerous readings.

Biosystems offers calibration kits and long lasting cylinders of test gas specifically developed for easy Ex Chek calibration. Customers are urged to use Biosystems calibration materials when calibrating the Ex Chek.

⚠️WARNING Use of non-standard calibration gas and/or calibration kit components when calibrating the Ex Chek can lead to dangerously inaccurate readings and may void the standard Biosystems warranty.

3.1.1 Effects of contaminants on combustible sensors

Combustible sensors may be affected by exposure to substances containing silicone (found in many lubricants and hydraulic fluids), the tetra-ethyl-lead in "leaded" gasoline, and halogenated hydrocarbons (Freons[®], or solvents such as trichloroethylene and methylene chloride). High concentrations of hydrogen sulfide may also damage the sensor.

Note: If sensitivity of the combustible sensor is lost due to poisoning, it tends to be lost first with regards to methane.

A partially poisoned sensor might still respond accurately to propane while showing a dangerously reduced response to methane.

Biosystems' "Propane Equivalent" calibration gas mixtures have been developed to eliminate this potentially dangerous source of calibration error. Because Biosystems' "Propane Equivalent" mixtures are based on methane, any loss of sensitivity to methane is detected (and can be corrected) immediately.

Using Biosystems brand calibration gas and verifying accuracy before each day's use insures that proper sensitivity is maintained over the life of the sensor.

3.1.1.1 Effects of high concentrations of combustible gas on the combustible sensor

The accuracy of combustible sensors may also be affected by exposure to high concentrations of combustible gas. To minimize the chance for damage or loss of sensitivity to the combustible sensor, the Ex Chek is designed to "alarm latch" whenever the concentration of combustible gas exceeds 100 percent LEL. Under these conditions the combustible gas reading will show "F L T" to indicate an over-limit condition. The audible and visual alarms will sound continuously until the instrument is manually reset by turning it off, then turning the instrument back on in an area where the air is known to be fresh.

⚠️WARNING Make sure that the Ex Chek is located in fresh air before turning the instrument back on after a combustible sensor alarm latch condition has occurred. Fresh air calibration adjustments may only be made when the Ex Chek is located in air that is known to be fresh. After a combustible sensor alarm-latch condition occurs, the accuracy of the combustible gas sensor must be verified by exposure to known percentage LEL concentration test gas before further use.

⚠️WARNING The combustible sensor used in the Ex Chek requires a minimum of 10% oxygen by volume in order to generate accurate combustible gas readings. Combustible sensor accuracy may be diminished if the instrument is used in oxygen-deficient atmospheres.

⚠️WARNING A rapid up-scale reading followed by a declining or erratic reading may indicate a hazardous combustible gas concentration that exceeds the Ex Chek's zero to 100 percent LEL detection range. Failure to

leave the area immediately may result in serious injury or death!

Avertissement: Toute lecture rapide et positive, suivie d'une baisse subite au erratique de la valeur, peut indiquer une concentration de gaz hors gamme de détection qui peut être dangereuse.

3.2 Fresh air "zero" calibration

The fresh air "zero" must be done in fresh, uncontaminated air. In this procedure the instrument automatically adjusts its readings to match the concentrations present in fresh air. Fresh air should contain 20.9% oxygen, no combustible gases or vapors and no toxic gases.

If the Ex Chek cannot be taken to an area where the air is fresh, or if it is not certain whether or not the air is uncontaminated, special procedures are required.

Appendix A discusses calibration options in contaminated air.

The second step is to verify the accuracy of the sensor by exposing it to known concentration test gas.

3.3 Functional (bump) test

A simple functional (bump) test is all that is needed to verify accuracy.

To perform a functional (bump) test, turn the Ex Chek on, and wait at least three minutes to allow the readings to fully stabilize. Make sure the instrument is located in fresh air. Check to see that the readings match the concentrations present in fresh air. If the Ex Chek is operated in the **Technician** mode readings should equal 0% LEL. If the instrument is operated in the Text Only mode all readings should indicate conditions are "OK". If necessary, fresh air zero the instrument using the procedures discussed in **Section 3.4.1**.

Slip on the calibration adapter as discussed in **Section 3.4.2**, and flow calibration gas to the sensor. Wait for the readings to

stabilize. (Forty-five seconds to one minute is usually sufficient.) Note the readings. LEL readings are considered accurate when they are within $\pm 10\%$ of the expected concentration as given on the calibration gas cylinder. If readings are accurate, there is no need to adjust your gas detector. If the readings are inaccurate, the instrument must be span calibrated before further use.

Note: It is necessary to be in the Technician operating mode in order to make calibration adjustments. When the instrument is operated in the Text Only "OK" mode a functional (bump) test is the procedure used to verify accuracy. If the readings are accurate, it is safe to use the instrument without further adjustment.

3.4 Auto-calibration

Biosystems "One-Button Auto-Calibration" mode may be used to verify accuracy any time during normal operation while the instrument is being used in the **Technician** operating mode.

Press the on / off MODE button 3 times in rapid succession to enter the "Auto-Calibration" mode.

Auto-calibration is a two step procedure. In the first step the Ex Chek is taken to an area where the atmosphere is fresh and a "zero" adjustment is made automatically by pressing the on / off MODE button. The second step is the sensor response or "span" calibration adjustment. In this step the accuracy of the Ex Chek sensor is established by exposing it to known concentration calibration gas. Once again, the sensitivity or "span" is automatically adjusted by pressing the on / off MODE button.

3.4.1 Fresh air "zero" auto-calibration sequence

The fresh air zero procedure may only be done while the instrument is being operated in the **Technician** operating mode.

- (1) Turn the instrument on and make sure gas readings are given in numbers.
If readings are given in the form of "OK" text messages the instrument is currently being operated in the "Text Only" mode. It will be necessary to change to the **Technician** operating mode. Switch modes (if necessary) by simultaneously holding down the "+" and "-" key as discussed in section 2.2.3. Each time the operating mode is changed, the LCD screen will briefly indicate the current operating mode.
- (2) Wait at least three minutes after turning the instrument on to allow sensor readings to stabilize fully before initiating auto-calibration procedures.
- (3) Make sure the instrument is located in an area where the air is known to be fresh.
- (4) Press the MODE button 3 times within two seconds. This will "wake up" the instrument from normal operation, and put it into the "Auto-Calibration" mode.
A screen will briefly display the message "ZERO MODE".

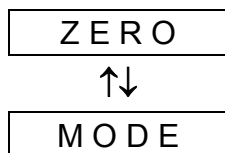

- (5) Pressing the MODE button within five seconds causes the fresh air adjustment to be made. (If the MODE button is not pushed within 5 seconds, the instrument will return to normal operation.)

The screen will show the message "WAIT ZERO" while the adjustment is being completed.

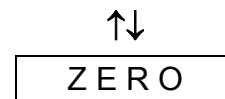

- (6) After successful completion of the "zero" calibration, the display will prompt you with the message "SPAN MODE" to continue with a span calibration adjustment.

3.4.1.1 Reading "Too High" or "Too Low" for zero adjust

To reduce the chances of the Ex Chek being inadvertently zeroed in contaminated air, only small adjustments are allowed through the use of the "One Button" auto-zero sequence. If the necessary adjustments are too large the display will indicate that the reading is too low or too high for zero adjustment. In this case the instrument must be fresh air zeroed using the "Cal" button on the instrument keypad and procedures discussed in Section 3.5.1 of this manual. Once the instrument has been successfully zeroed using the "Cal" button, subsequent calibration adjustments may be made using the MODE button and "One Button Auto Cal" logic discussed in this section.

3.4.2 "Span" calibration sequence

After successful completion of the "zero" auto-calibration adjustment the display will show the message "SPAN MODE".

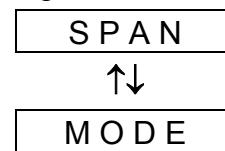

If the MODE button is not pushed within five seconds a span calibration adjustment will not be made, and the instrument will be returned to normal operation.

- (1) Press the MODE button within 5 seconds to initiate "span" auto-calibration. A screen will ask you to "FLOW GAS". The instrument will continue to display this screen until it determines that calibration gas has been applied.

Note: It is possible to exit the auto-calibration mode at any time prior to completion by pressing the MODE button.

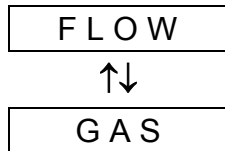

(2) Attach the cylinder of calibration gas, regulator, short section of tubing and calibration adapter to the Ex Chek detector.

⚠WARNING Make sure the regulator, cylinder seating surfaces and threads are clean and dry before attaching the regulator to the cylinder of gas. Introduction of contaminants through the regulator fittings may alter or degrade the concentration of the gas contained in the cylinder and may lead to inaccurate and potentially dangerous gas readings.

The regulator will automatically begin flowing calibration gas at the correct flow rate as soon as it is screwed into the cylinder of gas.

(3) The instrument will display the sensor readings as they rise. When they have stabilized at their highest value, the instrument will note the response and, if necessary, adjust the readings to match the calibration gas concentration values as they are entered in the instrument. (The instrument will beep as the adjustment is being made.)

The instrument's calibration gas value settings are discussed in chapter 5.

Verify that the concentration printed on the label of the calibration gas cylinder matches the concentration shown on the "Span Adjust" screen as the sensor is adjusted. If the concentration does not match it will be necessary to assign a new calibration gas concentration as

discussed in Chapter 5 before continuing with the auto-span adjustment.

(4) Once the span adjustment has been successfully completed, the display will show the message "DONE" and the instrument will return to the gas current gas readings screen.



Note: Remove the calibration adapter and all other fittings from the Ex Chek before returning the instrument to service.

3.5 Manual calibration procedure

It is also possible to calibrate the Ex Chek manually using the four buttons on the instrument keypad.

3.5.1 Fresh air "zero" through keypad buttons

- (1) Turn the instrument on.
- (2) Wait at least three minutes after turning the instrument on to allow sensor readings to stabilize fully before initiating the fresh air zero procedure.
- (3) Slide the belt clip towards the rear of the instrument to expose the four buttons on the instrument keypad.
- (4) Verify that the instrument is in the Technician operating mode. Switch modes (if necessary) by simultaneously holding down the "+" and "-" keys.
- (5) Make sure the instrument is located in an area where the air is known to be fresh.
- (6) Press the keypad button marked "Cal". The "GAS ZERO" calibration message will appear on the instrument LCD.

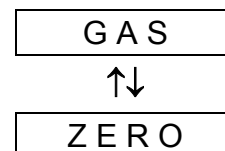

(7) Press "Cal" to automatically zero the instrument. The LCD will show the

message "ZERO WAIT" while the adjustment is being made.

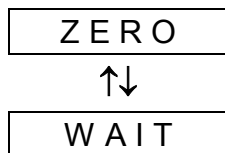

- (8) To cancel, press the MODE button. This causes the calibration values in the memory to remain unchanged from the last time a fresh air adjustment was made. An information screen is displayed briefly which verifies that the zero values have not been changed. The instrument will then return to normal operation.

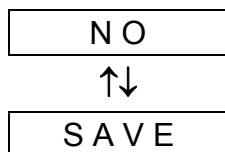

- (9) After completion of the zero adjustment the Ex Chek automatically returns to the gas readings screen.

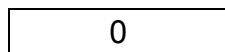

3.5.2 Span calibration using keypad buttons

Span calibration procedures using buttons on the instrument keypad are only necessary when the adjustment necessary to restore accuracy is outside the permissible window of adjustment for "One Button Auto Calibration" procedures. Span calibration using the keypad buttons may only be done while in the **Technician** operating mode.

- (1) Turn the instrument on.
- (2) Remove the belt clip by sliding it free from the belt clip mounts to expose the four mini-push-buttons.
- (3) Verify that the instrument is in the **Technician** operating mode. Switch modes (if necessary) by simultaneously holding down the "+" and "-" keys.

- (4) Each time that the operating mode is changed, the LCD screen will briefly indicate the current operating mode.
- (5) Turn the instrument off by pressing the MODE button for three full seconds.
- (6) With the unit turned off, press and hold down the "Cal" button.
- (7) While holding down the "Cal" button, press the MODE button to turn the Ex Chek back on. A screen showing the message "SPAN" will be displayed which alternates with the sensor readings.

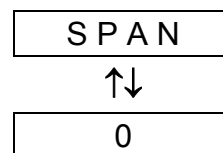

Press the MODE button at any time to cancel the calibration mode.

- (7) Attach the cylinder of gas, regulator, short section of tubing and calibration adapter to the Ex Chek.

⚠WARNING Make sure the regulator, cylinder seating surfaces and threads are clean and dry before attaching the regulator to the cylinder of gas. Introduction of contaminants through the regulator fittings may alter or degrade the concentration of the gas contained in the cylinder and may lead to inaccurate and potentially dangerous gas readings.

- (8) The regulator will automatically begin flowing gas at the correct flow rate as soon as it is fully inserted. When the readings stabilize, use the "+" and "-" keys to raise or lower the readings to match the concentration printed on the calibration cylinder label.

⚠WARNING Always check the expiration date on calibration gas cylinder(s) prior to use. Expired calibration gas can lead to inaccurate and potentially dangerous readings.

(9) Make sure the correct cylinder of gas is attached before attempting to adjust the span! If the concentration of gas reaching the sensor is too low to allow the instrument to be adjusted, or if the wrong type of gas is applied to the sensor being adjusted, the alarms will be activated and a screen will be displayed indicating that the instrument “CANT / SPAN”. Pressing the MODE button clears the “CANT SPAN” message and returns the instrument to normal operation.

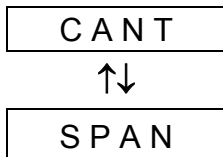

In the event that a “CANT SPAN” message is displayed, verify the type and concentration of the gas being used is correct for the sensor being calibrated, and replace the cylinder if necessary. Verify that the flow rate of the regulator is 1.0 lpm. If the "CANT SPAN" message is repeated it may indicate that the sensor requires replacement.

(10) When span calibration has been completed, press and hold the "Cal" button down until the LCD screen indicates that calibration is complete by showing the message “DONE”. The Ex Chek will then turn itself off.



The “Cal” button must be held down until the screen indicates that span calibration has been successfully completed.

If the button is released before this message is displayed, span values will not be updated, and remain unchanged from the last time a span calibration was successfully completed.

Pressing the MODE button at any time cancels the manual span calibration procedure. A screen will announce “NO

SAVE” after which the instrument will turn itself off.

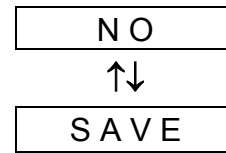

⚠WARNING A sensor that cannot be calibrated or is found to be out of tolerance should be replaced immediately. An instrument that fails calibration may not be used until testing with known concentration test gas determines that accuracy has been restored, and the instrument is once again fit for use.

Pressing the MODE button at any time during the span adjustment cancels the procedure, and causes the calibration values in memory to remain unchanged from the last time a span calibration adjustment was made.

Chapter 4. Alarm settings

Ex Chek alarms are user adjustable and may be set anywhere within the range of the sensor channel. When an alarm set point is exceeded a loud audible alarm sounds, the bright red LED alarm light blinks, and (if equipped) the optional vibrator alarm is activated.

Ex Chek alarms are normally self-resetting, that is, as soon as readings drop below the alarm set point, the alarm ceases. It is also possible to set Ex Chek alarms so that they "latch" once they are activated. In the latched condition, once an alarm occurs both visual and audible alarms continue to sound even after the atmospheric hazard has cleared. In a latched condition, the instrument must be manually reset by pressing the MODE button. Pressing the MODE button silences the alarms and restores normal operation.

Procedures for latching Ex Chek alarms are given in Section 5.3.7.

4.1 Alarm adjustment sequence

It is necessary to be in the "Alarm Adjust" mode before it is possible to change alarm settings. Once in this mode, any and all alarm set points are user adjustable.

In many cases it is possible to comply with OSHA guidelines while using higher alarm points than those used by Biosystems. It is important to note that the default alarm point settings used in the Ex Chek are very conservative in order to maximize worker safety.

To enter the alarm adjust mode, it is necessary to do the following.

- (1) Turn the instrument on and make sure it is in Technician Mode. (See Section 2.2.4.)
- (2) Turn the instrument off by pressing the MODE button for three full seconds.

- (3) With the unit turned off, press and hold down the "Alarm" button.
- (4) While holding down the "Alarm" button, press the MODE button to turn the Ex Chek back on.
- (5) A screen will appear showing the alarm point to be adjusted, and the current alarm set point.

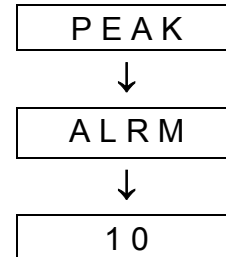

- (6) Use the "+" and "-" keys to raise or lower the alarm set point.
- (7) When the alarm adjustment has been completed, press and hold the "Alarm" button down until an information screen indicates that alarm adjustment is complete.



4.2 "Alarm Latch" command

Ex Chek alarms are normally self resetting, that is, as soon as readings drop below the alarm set point, the alarm ceases.

It is possible, if desired, to set Ex Chek alarms so that they "latch". In the latched condition, once an alarm occurs both visual and audible alarms continue to sound even after the atmospheric hazard has cleared. The instrument must be manually reset by pressing the MODE button. Pressing the MODE button silences the alarms and restores normal operation.

Use the following procedure to "latch" the Ex Chek alarms:

- (1) Make sure the Ex Chek detector is in the Technician mode (as discussed in Section 2.2.4), then turn the instrument off.

- (2) Turn the instrument on while pressing and holding down the "Alarm" button. This will place the instrument in the "Alarm Adjust Mode".
- (3) Use the "+" or "-" key to change the alarm latch setting.
- (4) Once the proper setting has been selected, press and hold down the "Alarm" button for three seconds. Do not release the "Alarm" button until the LCD displays the message "DONE" to indicate that the new setting has been successfully entered. Pressing the MODE button at any time cancels the procedure. The LCD will show the message "NO SAVE" to indicate that the setting has not been changed.

4.3 Restoring the factory default alarm settings

Ex Chek alarm settings are set at the factory in the most conservative way possible. It is possible to restore these default settings at any time by doing the following.

- (1) Turn the instrument on and make sure it is in the Technician Mode. (See Section 2.2.4.)
- (2) Press the "Alarm" button on the instrument key-pad. The display will briefly show the default alarm message, and the type of sensor currently installed.

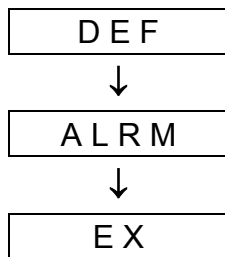

- (3) This screen will be followed by another screen showing the specific default alarm setting. This screen will be shown in continuous rotation.

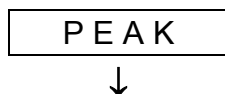

1 0

- (5) Push and hold the "Alarm" button to restore the factory default alarm settings. The display indicates when the settings have been restored:

D O N E

- (6) If the "Mode" button is pushed, the current alarm settings remain unchanged, and the display shows the following screen:

N O



S A V E

- (7) After selection of the default or current alarm settings has been made, the display reverts to the current gas reading screen.

Chapter 5. Ex Chek Advanced Functions

5.1 Advanced features overview

The Ex Chek microprocessor circuitry makes a number of advanced features and capabilities possible. Although this chapter has been designed primarily to benefit "experts" there are several sections that may be of interest to other Ex Chek users.

The four mini-push-buttons located under the keypad cover on the bottom of the detector are used to program advanced Ex Chek functions. The technique for using these buttons requires several buttons to be pressed and held at the same time.

Important: Do not use this technique with any other combination of buttons than those listed below. Doing so may result in unintended changes to the instrument setup.

5.2 Re-setting the calibration gas concentration

During auto calibration the Ex Chek adjusts the sensitivity of the sensor to match the concentration of the gas used to calibrate the sensor. The value the instrument uses to adjust the reading is the calibration gas concentration stored in the instrument memory.

For instance, Biosystems normally supplies 50% of the lower explosive limit (LEL) propane equivalent gas for use in calibrating the Ex Chek detector. This is the default calibration gas concentration stored in the instrument memory. When gas is applied to the sensor during auto calibration, the instrument automatically adjusts the sensitivity of the Ex Chek combustible sensor to 50% LEL.

⚠WARNING Do not reset the calibration gas concentration unless you are using a calibration gas concentration

that differs from the one that is normally supplied by Biosystems for use in calibrating the Ex Chek

Biosystems offers calibration kits and long-lasting cylinders of test gas specifically developed for easy Ex Chek calibration. Customers are strongly urged to use only Biosystems calibration materials when calibrating the Ex Chek.

Use the following procedure to re-set the calibration gas concentration:

- (1) Make sure the Ex Chek detector is in the Technician mode (as discussed in Section 2.2.4) then turn the instrument off.
- (2) Turn the instrument on while pressing and holding down the "+" button. The Ex Chek LCD will display alternating "CAL" and "GAS" messages for 4 seconds. The display will then alternate between the current concentration stored in memory and the "GAS" message screens.
- (3) Use the "+" and "-" buttons to change the gas concentration.
- (4) Once the proper new concentration has been selected, press and hold down the "Alarm" button for three seconds. Do not release the "Alarm" button until the LCD displays the message "DONE" to indicate that the new value has been successfully entered.

Pressing the MODE button at any time cancels the procedure. The LCD will show the message "NO SAVE" to indicate that the calibration gas concentration values have not been changed.

5.3 Setting the security beep interval

The security beep screen allows the Ex Chek to be programmed to emit an audible alarm "beep" on a regular basis while the

instrument is in operation. This periodic beep serves as a reminder that the instrument is on.

Use the following procedure to turn the security beep on:

- (1) Make sure the Ex Chek detector is in Technician mode (as discussed in Section 2.2.4) then turn the instrument off.
- (2) Turn the instrument on while pressing and holding down the “-” button.
- (3) The Ex Chek LCD will display alternating “SEC” and “BEEP” messages for 4 seconds. The display will then alternate between the current security beep interval in minutes and the message “MIN”.
- (4) Use the “+” and “-” buttons to set the security beep interval (the time between beeps).
The interval may be set in one-minute increments to any value between 0 and 60 minutes. Setting the interval to 0 disables the security beep.
- (5) Once the proper setting has been selected, press and hold down the “Alarm” button for three seconds. Do not release the “Alarm” button until the LCD displays the message “DONE” to indicate that the new setting has been successfully entered.

Pressing the MODE button at any time cancels the procedure. The LCD will show the message “NO SAVE” to indicate that the setting has not been changed.

Chapter 6. Trouble Shooting and Repair

6.1 Replacing Ex Chek sensor

⚠WARNING The Ex Chek must be calibrated immediately following any sensor change. Failure to calibrate the Ex Chek after a sensor change may lead to inaccurate and potentially dangerous readings.

To replace a sensor:

- (1) Make sure the Ex Chek is turned off.
- (2) Gently unscrew (1/4 turn counter clockwise) and remove the protective sensor cap.
- (3) Remove the o-ring around the sensor then, gently pry the sensor out of its socket.
- (4) Make sure the pins are properly aligned and gently press the replacement sensor into place and realign and seat the o-ring around the sensor.
- (5) Make sure the correct filter in the protective sensor cap is replaced along with the new sensor. (A spare filter should have been supplied together with the replacement sensor.) Use a blunt object to push the old filter out of the sensor cap, and using a finger, press the new filter into place. Be careful not to rip the filter membrane.
- (6) Replace the protective sensor cap.
- (7) Allow at least three minutes for the sensor to stabilize.
- (8) Recalibrate the new sensor.

6.2 Troubleshooting

There are a few troubleshooting and repair procedures besides sensor and battery replacement which can be done in the field.

Caution: The following repair procedures should only be performed by authorized personnel.

6.3 Specific problems

6.3.1 Unit will not turn on

Possible causes:

Battery discharged, microprocessor / software malfunction.

Solution(s):

Take the instrument to a non-hazardous location. Recharge the batteries and attempt to turn on. If the instrument still fails to turn on, return to factory for repair.

6.3.2 Unit will not turn off

Possible causes:

Microprocessor / software malfunction, low or bad battery, faulty on / off mode switch.

Solution(s):

Take the instrument to a non-hazardous location, replace the batteries, and attempt to turn the detector back on. If the instrument fails to turn on, return to factory for repair.

6.3.3 Unstable sensor readings

Possible causes:

Loose connection, bad sensor, improper calibration, expired calibration gas.

Solution(s):

Check that the sensor is firmly in place. Check calibration gas dating. Recalibrate sensor. Replace sensor if necessary.

6.3.4 Blank display

Possible causes:

Battery voltage too low. Operating temperature too low. Bad LCD display assembly. Microprocessor locked-up or "crashed".

Solution(s):

Take the instrument to a non-hazardous location. If cold, allow instrument to warm back up to room temperature. Recharge the batteries and attempt to turn the

instrument back on. If the instrument still fails to turn on, return to factory for repair.

6.3.5 No audible alarm

Possible causes:

Loose connection, alarm failure.

Solution(s):

Return to factory for repair.

6.3.6 Keypad buttons (+,-, Cal, Alarm) don't work

Possible causes:

Not in **Technician** mode, microprocessor locked-up or "crashed", loose connection, switch failure.

Solution(s)

Switch to **Technician** operating mode. Take the instrument to a non-hazardous location. Replace the batteries and attempt to turn the instrument back on. If keypad buttons still fail to operate properly return to factory for repair.

6.3.7 Can't make a "One Button" auto zero adjustment ("Too High" or "Too Low" for zero adjust)

Possible causes:

The atmosphere in which the instrument is located is contaminated (or was contaminated at the time the instrument was last zeroed); instrument is still attached to calibration fittings; a new sensor has just been installed; instrument has been dropped or banged since last turned on.

Solution(s):

Remove any calibration gas fittings, take the instrument to fresh air and allow readings to stabilize. Do a manual fresh air zero adjustment using buttons on the instrument keypad as discussed in **Section 3.5.1**.

6.4 Returning your Ex Chek to Biosystems for service or repair

Please contact the Biosystems Service Department at (860) 344-1079 to obtain a "Return Authorization" number prior to shipment. A Biosystems Service representative will record all relevant information or special instructions at that time.

To ensure safe transport please use the original Ex Chek packing materials, or other packing materials which similarly protect the instrument and accessories.

Note: The return authorization number must be clearly marked on the outside of the box.

Prominently showing the return authorization number on the outside of the box ensures that it is immediately identified and logged into our system at the time it is received. Proper tracking helps avoid unnecessary delays in completion of service procedures.

Please contact the Biosystems Service Department at (860) 344-1079 if you require any additional information.

Thank you for choosing the Ex Chek, and thank you for choosing Biosystems.

Appendicies

Appendix A: How to calibrate your Ex Chek in contaminated air

Calibration of the Ex Chek is a two-step process. The first step is to expose the sensors to contaminate-free fresh air and perform a fresh air calibration.

Unfortunately some locations are never completely free of contaminants. To make calibration easy in this case, it is necessary to use special calibration "Zero Contaminant" gas. This gas cylinder, Biosystems part number 9039, is used in conjunction with the sample draw calibration adapter.

Flow the zero contaminant gas across the sensors for a minute, just as if you were doing a span calibration. Then do the fresh air calibration steps described in Chapter 3 of the reference manual. Appendix B: Suggested Calibration Gases

⚠WARNING Use of non-standard calibration gas and/or calibration kit components when calibrating the Ex Chek can lead to dangerously inaccurate readings and may void the standard Biosystems warranty.

Biosystems offers calibration kits and long lasting cylinders of test gas specifically developed for easy Ex Chek

calibration. Customers are strongly urged to use only Biosystems calibration materials when calibrating their Ex Chek.

Part Number	Calibration gas mixture	Comments
54-9031	Methane (CH ₄) (2.5% by volume = 50% LEL in air)	Use when monitoring for presence of methane or natural gas only.
54-9032E	Propane Equivalent (50% LEL, in air)	Recommended for general purpose combustible gas monitoring.
54-9068E	Pentane Equivalent (50% LEL, in air)	Use when monitoring for presence of pentane or gasses with similar response ratios only.
54-9039	Zero air (20.9 % oxygen in nitrogen)	Use for fresh air calibration in contaminated areas.

Appendix B: Biosystems Standard Warranty Gas Detection Products

General

Biosystems, A Division of Bacou-Daloz Safety (hereafter Biosystems) warrants gas detectors, sensors and accessories manufactured and sold by Biosystems, to be free from defects in materials and workmanship for the periods listed in the tables below.

Abuse, mechanical damage, alteration, or repair procedures not made in accordance with the instrument Reference Manual void the Biosystems standard warranty.

The obligation of Biosystems under this warranty is limited to the repair or replacement of components deemed by the Biosystems Instrument Service Department to have been defective under the scope of this standard warranty. To receive consideration for warranty repair or replacement procedures, products must be returned to Biosystems at its manufacturing location in Middletown, Connecticut, with transportation and shipping charges prepaid. It is necessary to obtain a return authorization number from Biosystems prior to shipment.

This warranty is expressly in lieu of any and all other warranties and representations, express or implied, including but not limited to, the warranty of fitness for a particular purpose. Biosystems will not be liable for loss or damage of any kind connected to the use of its products or failure of its products to function or operate properly.

Instrument & Accessory Warranty Periods

Product(s)	Warranty Period
PhD ⁵ , PhD Lite, PhD Plus, PhD Ultra, Cannonball3, MultiVision, Toxi Vision and Toxi Series	As long as the instrument is in service
Mighty-Tox	90 days after activation or 90 days after the "Must Be Activated By" date, whichever comes first
Mighty-Tox 2 Mighty-Tox 2 prorated credit is given towards repair or purchase of a new unit.	0 – 6 months of use 100% credit 6 – 12 months of use 75% credit 12 – 18 months of use 50% credit 18 – 24 months of use 25% credit
Series 3000, Airpanel, Travelpanel, ZoneGuard, Gas✓Chek1 and Gas✓Chek4	One year from the date of purchase
Battery packs and chargers, sampling pumps, and other components, which by their design are consumed or depleted during normal operation, or which may require periodic replacement	One year from the date of purchase

Sensor Warranty Periods

Instrument(s)	Sensor Type(s)	Warranty Period
PhD ⁵ , PhD Lite, Cannonball3	O ₂ , LEL**, CO, CO+, H ₂ S & Duo-Tox	2 Years
	All Other Sensors	1 Year
PhD Plus, PhD Ultra, Toxi Vision, MultiVision	O ₂ , LEL**, CO, CO+, H ₂ S	2 Years
	All Other Sensors	1 Year
Toxi Series	LEL**, CO, CO+, H ₂ S	2 Years
	All Other Sensors	1 Year
All Others	All Sensors	1 Year

** Damage to combustible gas sensors incurred by exposure to known sensor poisons such as silicone and siliconized caulks/sealants (a.k.a. RTV - Room Temperature Vulcanizing), silicone rubber molded products & coatings, greases for laboratory glassware (stopcock, ground glass joints, etc.), toner fusing agent in photocopiers, die lubricants in cutting, stamping or other material converting operations, heat transfer fluids in fine chemical & pharmaceutical manufacture, lubricants, waxes & polishing compounds (neat or spray aerosols), mold release agents for plastics injection molding operations, waterproofing formulations, vinyl & leather preservatives, or release papers used as the backings of pressure sensitive adhesive backed roll or sheet goods may (at the discretion of Biosystems Instrument Service Department) void Biosystems' Standard Warranty as it applies to the replacement of combustible gas sensors.