

Biosystems is now



Toxi Vision

**Single Gas
Detector**

Reference Manual



**Sperian Instrumentation
651 South Main Street
Middletown, CT 06457
(800) 711-6776
(860) 344-1079
Fax (860) 344-1068
Part number 13-204
Version 3.00
25OCT2007**

WARNING

THE TOXI VISION PERSONAL PORTABLE GAS DETECTORS HAVE BEEN DESIGNED FOR THE DETECTION AND MEASUREMENT OF POTENTIALLY HAZARDOUS ATMOSPHERIC CONDITIONS.

IN ORDER TO ASSURE THAT THE USER IS PROPERLY WARNED OF POTENTIALLY DANGEROUS ATMOSPHERIC CONDITIONS, IT IS ESSENTIAL THAT THE INSTRUCTIONS IN THIS REFERENCE MANUAL BE READ, FULLY UNDERSTOOD, AND FOLLOWED.

**Toxi Vision Reference Manual
Sperian Protection Instrumentation
Part Number 13-204
Version 3.00
Copyright 2007
by
Sperian Protection, LLC
Middletown, Connecticut 06457**

All rights reserved.

No page or part of this operation manual may be reproduced in any form without written permission of the copyright owner shown above.

Sperian Instrumentation reserves the right to correct typographical errors.

Table of Contents

Certifications	3
Warnings and Cautions	3
A. Signal Words.....	3
B. Warnings.....	4
1. Overview	5
1.1 Methods of sampling	5
1.2 Sensors.....	5
1.2.1 Toxic sensor ranges	5
1.2.2 Oxygen sensor ranges	5
1.3 Alarm logic	5
1.3.1 Gas alarms.....	5
1.3.2 Low battery alarms	5
1.4 Calibration.....	5
1.5 Features.....	5
1.5.1 Security Beep	5
1.5.2 STEL and TWA display	6
1.6 Design components	6
1.7 Standard accessories.....	6
1.8 Value pack kits	6
2. Operation	7
2.1 Turning the Toxi Vision on.....	7
2.2 Backlight	7
2.3 MAX, STEL and TWA.....	7
2.4 Turning the Toxi Vision off.....	8
2.5 Low battery alarms	8
2.6 Sampling.....	8
2.6.1 Sample draw kit usage	8
3.1 Verification of accuracy	9
3.2 Effect of contaminants on Toxi Vision sensors	9
3.2.1 Effects of contaminants on oxygen sensors.....	9
3.2.2 Effects of contaminants on toxic gas sensors	9
3.3 Sensors capable of responding to more than one toxic gas.....	10
3.3.1 CO Plus Sensor	10
3.3.2 Sperian non-specific chlorine and chlorine dioxide sensors.....	10
3.3.2.1 Cl ₂ Non-Specific.....	10
3.3.2.2 ClO ₂ Non-Specific.....	10
3.4 Response (bump) testing	10
3.5 Fresh air/zero calibration.....	11
3.6 Span Calibration.....	12
3.7 Failure to calibrate.....	12
3.7.1 Forced fresh air/zero calibration	13

3.8	Fresh air calibration in a contaminated atmosphere	13
4.	PC Functions	14
4.1	Installing the Toxi Vision PC software	14
4.2	Connecting the Toxi Vision to the PC	14
4.3	Initializing the connection	14
4.4	Calibration gas settings	15
4.4.1	Change calibration gas settings.....	15
4.4.2	Restore default calibration gas settings.....	15
4.5	Features settings.....	15
4.5.1	STEL and TWA display	15
4.5.2	Security Beep.....	15
4.6	Alarm settings	16
5.	Maintenance.....	16
5.1	Replacing batteries	16
5.2	Replacing sensors.....	17
	Replacement sensor list.....	18
	Default toxic sensor calibration gas settings.....	18
	Exploded view and basic parts list.....	19
	Appendix A: Sensor Cross-Sensitivity Chart	20
	Appendix B Calibration Frequency Recommendation	21
	Sperian Instrumentation Warranty Gas Detection Products	22

Certifications

The ToxiVision carries the following certifications:

UL Class I Division 1 Groups A,B,C,D Temp Code T4

C-UL Class I Division 1 Groups A,B,C,D Temp Code T4

CE Mark

ATEX Certification:

II 2G EEx ia IIC T4

UL International DEMKO A/S 03 ATEX 130959X

Warnings and Cautions

A. Signal Words

The following signal words, as defined by ANSI Z535.4-1998, are used in the Toxi Vision Operator's Guide.

⚠ DANGER indicates an imminently hazardous situation which, if not avoided, will result in death or serious injury.

⚠ WARNING indicates a potentially hazardous situation which, if not avoided, could result in death or serious injury.

⚠ CAUTION indicates a potentially hazardous situation, which if not avoided, may result in moderate or minor injury.

CAUTION used without the safety alert symbol indicates a potentially hazardous situation which, if not avoided, may result in property damage.

B. Warnings

1. **⚠️WARNING** The Toxi Vision personal, portable gas detector has been designed for the detection of either oxygen deficiencies or specific toxic gas accumulations. An alarm condition indicates the presence of a potentially life-threatening hazard and should be taken very seriously.
2. **⚠️WARNING** In the event of an alarm condition it is important to follow established procedures. The safest course of action is to immediately leave the affected area, and to return only after further testing determines that the area is once again safe for entry. Failure to immediately leave the area may result in serious injury or death.
3. **⚠️WARNING** Use only Duracell MN1500 or Ultra MX1500, Eveready Energizer E91-LR6, Eveready EN91, Radio Shack 23-874* size AA 1.5V Alkaline batteries, Eveready CH15* or Radio Shack 23-149* size AA NiMH batteries, or Eveready L91*† AA 1.5V Lithium batteries. Substitution of batteries may impair intrinsic safety.

*Not for use with ATEX certified instruments. (ATEX is a European safety directive).

†Not CSA approved (CSA is the Canadian Standards Association (similar to UL in the United States)).

4. **⚠️WARNING** The accuracy of Toxi Vision instruments equipped with toxic gas sensors should be checked periodically with known concentration calibration gas. Failure to check accuracy can lead to inaccurate and potentially dangerous readings. Toxi Vision instruments equipped with oxygen sensors should be periodically calibrated in fresh air.
5. **⚠️WARNING** A sensor that cannot be calibrated or is found to be out of tolerance must be replaced immediately. An instrument equipped with a toxic gas sensor that fails calibration may not be used until testing with known concentration test gas determines that accuracy has been restored, and the instrument is once again fit for use. Instruments equipped with an oxygen sensor that fail calibration may not be used until testing with fresh air determines that accuracy has been restored and the instrument is once again fit for use.
6. **⚠️WARNING** Do not reset the calibration gas concentration setpoints in the Toxi Vision unless the concentrations of your calibration gas differ from the concentrations of the calibration gas that is normally supplied by Sperian Instrumentation for use in calibrating the Toxi Vision.
7. **⚠️WARNING** Use of non-standard calibration gas and/or calibration kit components when calibrating the Toxi Vision can lead to dangerously inaccurate readings and may void the standard Sperian Instrumentation warranty.

Sperian Instrumentation offers calibration kits and long-lasting cylinders of test gas specifically developed for easy calibration. Customers are strongly urged to use only Sperian Instrumentation calibration materials when calibrating the Toxi Vision.
8. **⚠️WARNING** Substitution of components may impair intrinsic safety.
9. **⚠️WARNING** For safety reasons the Toxi Vision must be operated by qualified personnel only. Read, understand and follow the directions set forth in this reference manual before operating the Toxi Vision.
10. **⚠️WARNING** The Toxi Vision has been tested for intrinsic safety in Explosive Gas/AIR(21.0% O₂) Only.

1. Overview

The Toxi Vision is a single sensor gas detector designed to detect either oxygen (O₂) or one of a variety of toxic gases. The Toxi Vision includes numerous features designed to meet specific user requirements. This chapter will broadly discuss the use and capabilities of the Toxi Vision.

1.1 Methods of sampling

The Toxi Vision may be used in either diffusion or sample-draw mode. In either mode, the gas sample must enter the sensor compartment for the instrument to register a gas reading.

See section 2.6 for detailed instructions concerning sampling.

1.2 Sensors

The Toxi Vision uses either an electrochemical toxic gas sensor or a galvanic oxygen sensor. Both types of sensor have been designed to minimize the effects of common interfering gases. These sensors provide accurate, dependable readings for gases commonly encountered in industrial applications.

1.2.1 Toxic sensor ranges

Specific toxic sensor ranges and resolutions are provided in the sensor replacement chart in section 5.3.

1.2.2 Oxygen sensor ranges

The oxygen sensor used in the Toxi Vision has a range of 0-30% by volume.

1.3 Alarm logic

1.3.1 Gas alarms

Toxi Vision gas alarms are user-adjustable and may be set anywhere within the range of the specific sensor type. When an alarm set point is exceeded a loud audible alarm sounds, and the bright red LED alarm light flashes.

The procedure for adjusting alarm settings is covered in section 3.6.

For Toxi Vision instruments equipped with an oxygen sensor, two oxygen alarm set points have been provided: one for low concentrations associated with oxygen deficiency and one for high concentrations associated with oxygen enrichment.

Toxi Vision instruments equipped with a toxic gas sensor have four alarm set points: Low, High, TWA (Time Weighted Average) and STEL (Short Term Exposure Limit).

Note: Access to the STEL and TWA screens must be enabled with the PC configuration software. See section 4.5.1 for details.

1.3.2 Low battery alarms

Whenever battery voltage is reduced to approximately 2.3 volts, the battery icon on the LCD will be displayed, indicating that a low battery condition exists.



When the battery voltage reaches approximately 2.0 volts, the audible alarm will be briefly activated and the instrument will proceed to shut itself off.

1.4 Calibration

The Toxi Vision features one-button fresh air/zero and span calibration functions.

Calibration procedures are discussed in detail in chapter 3.

1.5 Features

1.5.1 Security Beep

The Toxi Vision includes a security beep that can be enabled or disabled according to the needs of the user. If the security beep is enabled, the Toxi Vision will emit a short beep every 60 seconds to remind the user that the instrument is active.

Note: The security beep must be enabled with the PC configuration software. See section 4.5.2 for details.

1.5.2 STEL and TWA display

User access to the STEL and TWA display screens can be enabled or disabled according to the needs of the user.

Note: Access to the STEL and TWA screens must be enabled with the PC configuration software. See section 4.5.1 for details.

1.6 Design components

- (1) **Case:** The instrument is enclosed in a solid, metal-plated ABS case. A black EPDM gasket between the upper and lower sections of the case protects against leakage or exposure to liquids.
- (2) **Front face:** The front face of the instrument houses the graphics capable LCD display, sensor port, LED alarm and audible alarm port.
- (3) **LCD display:** The liquid crystal display (LCD) allows display of gas readings, messages and other information. A built-in backlight allows the display to be read even in low light conditions.
- (4) **Alarm light (LED):** A bright red LED (light-emitting diode) alarm light provides a visual indication of the alarm state. The light is visible from the front and top of the instrument.
- (5) **MODE button:** The large push-button on the left side of the instrument is called the MODE button. The MODE button is used to turn the Toxi Vision on and off, to turn on the backlight, to view the MAX, STEL and TWA screens and to access the automatic calibration sequences.
- (6) **Audible alarm orifice:** A cylindrical resonating chamber contains the loud audible alarm.
- (7) **Bottom surface:** The belt clip attaches to the bottom surface of the instrument.

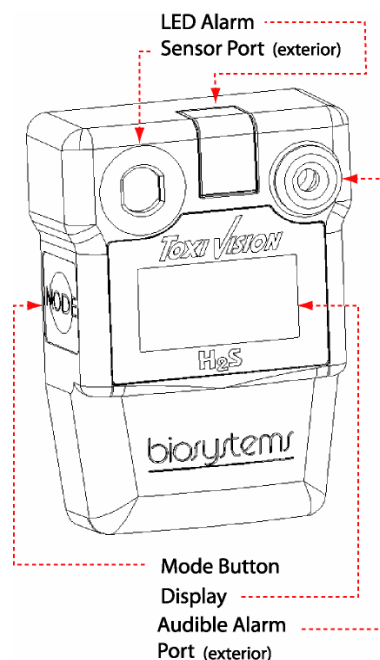

Figure 1.7 Exterior front view.

1.7 Standard accessories

Standard accessories with every Toxi Vision include installed sensor and set of 2 AA alkaline batteries, reference manual, quick reference card and calibration/sample draw adapter.

Optional accessories include manual (hand-aspirated) sample draw kit, PC software kit, and rubber boot.

Toxi Vision instruments that are not ordered in a value pack are delivered in a cardboard box.

1.8 Value pack kits

Toxi Vision value packs include all standard accessories, calibration fittings, 34-liter cylinder of calibration gas, and fixed flow rate regulator in a foam-lined, hard-shell carrying case.

2. Operation

Field operation of the Toxi Vision is controlled entirely through the MODE button, which is located on the left side of the instrument.

The MODE button is used to turn the Toxi Vision on and off, to turn on the backlight, to access MAX, STEL and TWA gas readings for the current session and to initiate the fresh air/zero and span calibration functions.

Note: Access to the STEL and TWA screens must be enabled with the PC configuration software. See section 4.5.1 for details.

2.1 Turning the Toxi Vision on

Press and hold the MODE button until the following display test screen is shown, then release the MODE button.



At start-up, the Toxi Vision will automatically go through a basic electronic self-test and start-up sequence that will take approximately thirty seconds. During the self-test sequence, the display backlight will momentarily turn on.

The Toxi Vision will then display the software version, followed by the sensor type.



The low alarm levels will then be displayed, followed by the high alarm levels. The instrument will also test the low and high audible alarms.

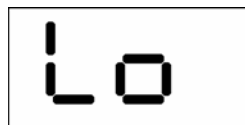

↑ Alternate 3 times ↓

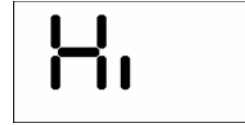

↑ Alternate 3 times ↓

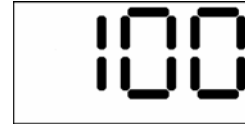

The current gas reading will then be displayed.



2.2 Backlight

The Toxi Vision includes a backlight that is automatically turned on during an alarm condition. The backlight can also be manually activated while the current gas reading is displayed by pressing the MODE button once. The backlight will automatically turn itself off in about twenty seconds.

2.3 MAX, STEL and TWA

From the current gas reading screen, press the MODE button once to activate the backlight and then once more to view the MAX value screen. The MAX value represents the highest reading recorded by the instrument during the current operating session.



Once the MAX screen is shown, press the MODE button again to view the current STEL reading. The STEL value displayed is the average concentration of gas readings for the most recently completed 15 minutes of operation.

Note: Access to the STEL and TWA screens must be enabled with the PC configuration software. See section 4.5.1 for details.



With the STEL screen shown, press the MODE button once more to view the current TWA value. Time Weighted Average or TWA values are calculated by taking the sum of exposure to a particular toxic gas in the current operating session in terms of parts-per-million-hours and dividing by an eight-hour period.



2.4 Turning the Toxi Vision off

To turn the Toxi Vision off, press and hold the MODE button down until the instrument beeps three times and OFF is displayed.



Once OFF is displayed, release the MODE button. The instrument has been successfully turned off when the display goes blank.

2.5 Low battery alarms

Whenever battery voltage is reduced to approximately 2.3 volts, the battery icon on the LCD will be displayed, indicating that a low battery condition exists.



When the battery voltage reaches approximately 2.0 volts, the audible alarm will be briefly activated and the instrument will proceed to shut itself off.

2.6 Sampling

The Toxi Vision may be used in either diffusion or sample-draw mode. In either mode, the gas sample must enter the sensor compartment for the instrument to register a gas reading.

In diffusion mode, the atmosphere reaches the sensor by diffusing through the sensor port on the front of the

instrument. Normal air movements are enough to carry the sample to the sensor. The sensor reacts quickly to changes in the concentration of the gas being measured.

It is also possible to use the Toxi Vision to sample remote locations with the hand-aspirated sample-draw kit that is available separately. During remote sampling, the gas sample is drawn into the sensor compartment through the probe assembly and a length of tubing.

2.6.1 Sample draw kit usage

1. Connect the end of the hose that is closer to the squeeze bulb to the sample draw adapter. Then connect the other end of the hose to the sample probe.
2. Attach the sample draw adapter to the ToxiVision.
3. Cover the end of the sample draw probe assembly with a finger, and squeeze the aspirator bulb. If there are no leaks in the sample draw kit components, the bulb should stay deflated for a few seconds.
4. Insert the end of the sample probe into the location to be sampled.
5. Squeeze the aspirator bulb several times to draw the sample from the remote location to the sensor compartment. Allow one squeeze of the bulb for every one foot of sampling hose for the sample to reach the sensors. Continue to squeeze the bulb for an additional 45 seconds or until readings stabilize.
6. Note the gas measurement readings.

CAUTION: Hand aspirated remote sampling only provides continuous gas readings for the area in which the probe is located when the bulb is being continuously squeezed.

Note: Each time a reading is desired, it is necessary to squeeze the bulb a sufficient number of times to bring a fresh sample to the sensor compartment.

3. Calibration

The Toxi Vision features fully automated fresh air/zero and span calibration functions. The MODE button is used to initiate the automatic calibration sequence. Calibration adjustments are made automatically by the instrument.

3.1 Verification of accuracy

Verification of accuracy for Toxi Vision instruments equipped with an oxygen sensor is a one step procedure. Simply take the Toxi Vision to an area where the atmosphere is known to be fresh and check the readings. If the readings differ from those expected in fresh air, then a fresh air/zero calibration adjustment must be made as discussed below in section 3.5. If fresh air is not available, see section 3.8 below for instructions on calibration in contaminated air.

For Toxi Vision instruments equipped with a toxic gas sensor calibration is a two step procedure.

Step one is to take the Toxi Vision to an area where the atmosphere is known to be fresh and check the readings. If the readings differ from those expected in fresh air, then a fresh air calibration adjustment must be made as discussed below in section 3.5.

Step two is to make sure the sensors are accurate by exposing them to a test gas of known concentration and noting the sensor response. The reading is considered to be accurate when the display is between 90% and 120% of the expected value for the gas being used. If readings are considered accurate, there is no need to adjust your gas detector. If the readings are inaccurate, the instrument must be span calibrated before further use as discussed in section 3.6.

⚠WARNING Accuracy of the Toxi Vision should be checked periodically with known concentration calibration gas. Failure to check accuracy can lead to inaccurate and potentially dangerous readings.

3.2 Effect of contaminants on Toxi Vision sensors

The atmosphere in which the Toxi Vision is used can have lasting effects on the sensors. Sensors may suffer losses in sensitivity leading to degraded performance if exposed to certain substances.

There are two basic types of sensors that may be installed in the Toxi Vision: galvanic oxygen or electrochemical toxic. Each type of sensor uses a slightly different detection principle, so the kinds of conditions that affect the accuracy of the sensors vary from one sensor to the next.

3.2.1 Effects of contaminants on oxygen sensors

Oxygen sensors may be affected by prolonged exposure to "acid" gases such as carbon dioxide. The oxygen sensors used in Sperian instruments are not recommended for continuous use in atmospheres containing more than 25% CO₂.

3.2.2 Effects of contaminants on toxic gas sensors

Sperian's "substance-specific" electrochemical sensors used to measure CO, H₂S, PH₃, SO₂, NH₃, Cl₂, ClO₂, HCN, NO and NO₂ have been carefully designed to minimize the effects of common interfering gases.

"Substance-specific" sensors are designed to respond only to the gases that they are supposed to measure. The higher the specificity of the sensor, the less likely the sensor will react to other gases, which may be incidentally present in the environment. For instance, a "substance-specific" Carbon Monoxide sensor is deliberately designed not to respond to other gases that may be present at the same time, such as hydrogen sulfide (H₂S) and methane (CH₄).

Although great care has been taken to reduce cross-sensitivity, some interfering gases may still have an effect on toxic sensor readings. In some cases the interfering effect may be positive and result in readings that are higher than

actual. In other cases the interference may be negative and produce readings that are lower than actual and may even cause the instrument to display negative readings for the target gas.

See Appendix A for cross-sensitivity data.

3.3 Sensors capable of responding to more than one toxic gas

In most cases, sensors are designed to minimize cross-sensitivity to other gases, but there are a few instances in which cross sensitivity is used to expand the utility of the detector.

The OSHA standard for permit-required confined space entry (29 CFR 1910.146) explicitly requires the use of a direct-reading, substance-specific sensor whenever a particular toxic hazard is likely to be present. For example, if carbon monoxide is likely to be present, one of the toxic sensors selected should be specifically designed for the detection of CO, and should be directly calibrated for the measurement of CO.

3.3.1 CO Plus Sensor

The two most common toxic gas hazards in confined space entry are carbon monoxide and hydrogen sulfide. Toxi Vision instruments are available with Biosystem's CO Plus sensor, which is designed to respond to both carbon monoxide and hydrogen sulfide, but can only be directly calibrated for the measurement of CO.

A properly calibrated Toxi Vision with a "CO Plus" sensor will accurately and directly measure carbon monoxide. OSHA has assigned an 8-hour TWA (Time Weighted Average) of 35 PPM as the permissible exposure limit for Carbon Monoxide. If the "CO Plus" sensor is successfully calibrated to Carbon Monoxide, and then exposed to 35 PPM Carbon Monoxide, the display will show 35 PPM.

The "CO Plus" sensor will also show a "relative response" to other interfering gases. When properly calibrated with carbon monoxide, the "CO Plus" sensor will also respond to Hydrogen Sulfide in a

ratio of about 3.5 to 1.0. This means that a concentration of about 10 PPM Hydrogen Sulfide would produce a reading of 10×3.5 or 35 PPM in an instrument that has been calibrated to CO.

This is a very convenient relative response. The 8-hour TWA permissible exposure limit for Hydrogen Sulfide is 10 PPM. This means that the CO Plus gas alarms will be tripped any time the concentration of Hydrogen Sulfide exceeds the permissible exposure limit.

3.3.2 Sperian non-specific chlorine and chlorine dioxide sensors

Sperian Instrumentation currently offers four sensors designed for the detection of chlorine and chlorine dioxide. Two of these sensors are "non-specific", meaning that they are designed to respond to both chlorine (Cl_2) and chlorine dioxide (ClO_2).

3.3.2.1 Cl_2 Non-Specific

The Cl_2 non-specific sensor is cross sensitive to ClO_2 at a rate of 3.1 to 1. This means that when a properly calibrated Toxi Vision with a Cl_2 non-specific sensor encounters 1PPM ClO_2 , it will respond by giving a reading of 3.1PPM Cl_2 .

3.3.2.2 ClO_2 Non-Specific

The ClO_2 non-specific sensor is cross sensitive to Cl_2 at a rate of 1 to 3.1. This means that when a properly calibrated Toxi Vision with a ClO_2 non-specific sensor encounters 1PPM Cl_2 , it will respond by giving a reading of approximately 0.3PPM ClO_2 .

Note: For more information on cross sensitivity for any of the sensors available in the Toxi Vision, see Appendix A.

3.4 Response (bump) testing

The accuracy of toxic sensor-equipped instruments may be verified at any time by a simple functional (bump) test.

To perform a response (bump) test, do the following:

1. Turn the Toxi Vision on and wait at least three minutes to allow the readings to fully stabilize.
2. Make sure the instrument is located in fresh air.
3. Verify that the current gas readings match the concentrations present in fresh air. The reading for toxic gases should be 0 parts-per-million (PPM) in fresh air. The reading for instruments equipped with an oxygen sensor should be 20.9%.
4. Apply the calibration gas as shown below in figure 3.4. (toxic sensor units only)
5. Wait for the readings to stabilize. (Forty-five seconds to one minute is usually sufficient.)
6. Note the readings. Readings are considered sufficiently accurate if they are between 90% and 120% of the expected reading. If the readings are considered accurate, then the instrument may be used without further adjustment.

For further instructions on calibration frequency recommendations and a more detailed explanation of accuracy requirements, see Appendix B.

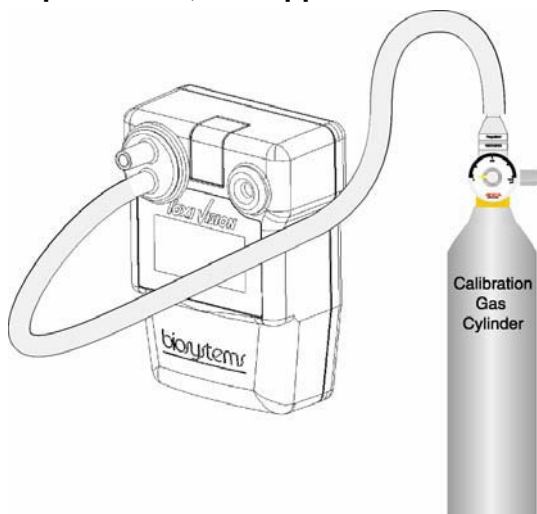

Figure 3.4: Proper bump-test/span calibration set-up for toxic sensor-equipped instruments.

Note: If gas concentration readings are off by more than 10 percent higher or lower than the expected values during a functional (bump) test, the instrument must be adjusted using the “span” calibration procedures

discussed in section 3.6 before further use.

3.5 Fresh air/zero calibration

To initiate the fresh air/zero calibration procedure:

1. From the current gas reading screen, press the MODE button three times within two seconds to begin the fresh air/zero calibration sequence. The Toxi Vision will briefly display “CAL” and then begin a 5 second countdown.

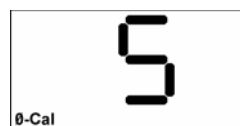
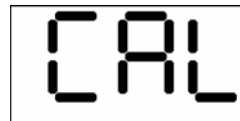

2. Press the MODE button before the end of the 5-second countdown to begin the fresh air/zero calibration. The fresh air/zero calibration has been successfully initiated when the Toxi Vision alternates between the following two screens:

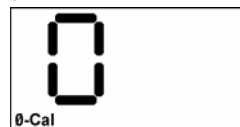

↑ Alternating ↓



3. For instruments equipped with a toxic gas sensor, the fresh air/zero calibration is complete when the instrument begins another 5-second countdown for the span calibration. If span calibration is not required, allow the countdown to reach 0 without pressing the MODE button.

If the instrument is equipped with an oxygen sensor, calibration is complete when the instrument returns to the current gas readings screen.

⚠WARNING Fresh air/zero calibrations may only be performed in an atmosphere that is known to contain 20.9% oxygen and 0 PPM

toxic gas. Performing fresh air/zero calibrations in an atmosphere that is not composed of 20.9% oxygen and 0 PPM toxic gas may lead to inaccurate and potentially dangerous readings.

3.6 Span Calibration

To perform a span calibration of instruments equipped with a toxic gas sensor, first perform a fresh air/zero calibration as discussed above in section 3.5. After successful completion of the fresh air/zero calibration, the instrument will begin a second five-second countdown with the calibration gas bottle icon highlighted.



1. Press the MODE button before the countdown is complete to initiate the span calibration. The display will alternate between "GAS" and the expected concentration of calibration gas.



↑ Alternating ↓



2. Apply calibration gas as shown above in figure 3.4. Once calibration gas is detected, the readout will change to show the gas reading.



3. The calibration is fully automatic from this point on. Once the instrument successfully completes the span calibration, it will emit three short beeps and display the maximum span calibration value for two seconds.



Note: The max span calibration adjustment value shown is an indication of the relative health of the sensor. As a sensor loses sensitivity, the maximum adjustment level will approach the calibration gas concentration, letting you know when the sensor is losing sensitivity. Once the maximum span adjustment is within 10% of the calibration gas concentration, it is time to order a new sensor.

4. The instrument will then return to normal operation.

Note: Once the calibration cycle is completed, the Toxi Vision automatically returns to normal operation and the gas alarms may be activated. Disconnect the calibration assembly immediately after calibration.

⚠WARNING Use of non-standard calibration gas and/or calibration kit components when calibrating the Toxi Vision can lead to inaccurate and potentially dangerous readings, and may void the standard Sperian Instrumentation warranty.

3.7 Failure to calibrate

In the event of calibration failure, the "no" and "CAL" screens will be alternately displayed as shown below before the instrument returns to the gas reading screen.

Fresh air/zero calibration failures often result from the attempt to calibrate the instrument in a contaminated atmosphere.



↑ Alternating ↓



In the case of a span calibration failure, the "no" and "CAL" screens will be shown with the calibration bottle icon highlighted.

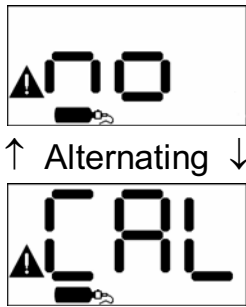

Span calibration failures can be caused by the following:

1. Expired calibration gas.
2. Calibration gas whose concentration fails to match the concentration expected by the instrument.
3. Sensor failure.

After a failed calibration attempt, the warning icon will appear in the current gas reading screen until a successful calibration is made.



The Toxi Vision will also emit a beep every 10 seconds and display the 0-cal or span cal icon to show which type of calibration failure has occurred.



or

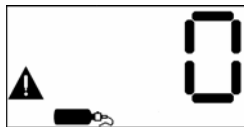

3.7.1 Forced fresh air/zero calibration

If a fresh air/zero calibration fails in an atmosphere known to be fresh, the Toxi Vision can be forced to fresh air calibrate as follows.

1. Follow instructions 1 and 2 in section 3.5 to begin the fresh air/zero calibration sequence.
2. As soon as the alternating right and left 0's are shown on the screen, press and hold the MODE button.

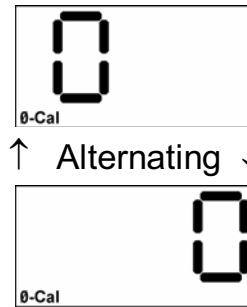

3. The forced fresh air/zero calibration is complete when the instrument emits three short beeps and then moves on the span calibration procedure.

3.8 Fresh air calibration in a contaminated atmosphere

To calibrate in a contaminated atmosphere, it is necessary to use special calibration gas, whose composition is identical to that of fresh air. Sperian Instrumentation offers the "Zero Air" calibration gas cylinder as part number 54-9039, which contains 0 PPM toxic gas and 20.9% oxygen.

1. Apply "Zero Air" calibration gas to the instrument as shown above in figure 3.5 for at least 15 seconds or until the readings fully stabilize.
2. Perform the fresh air/zero calibration procedure as described in section 3.5.
3. Once the fresh air/zero calibration is complete, disconnect the calibration assembly and move on to the span calibration if necessary as described in section 3.6.

4. PC Functions

The Toxi Vision's instrument settings are controlled through the Toxi Vision PC software, which is available separately.

4.1 Installing the Toxi Vision PC software

1. Place the CD-ROM into your computer's CD tray and close the tray. If the software fails to set itself up immediately, use Windows Explorer to run "setup.exe" on the CD-ROM drive.
2. At the first prompt, press the "Next" button.



3. At the second prompt, press the "Next" button.



4. To immediately launch the program, at the third prompt, check the "Yes, Launch the program file" checkbox followed by "Finish" button



5. To complete the installation without launching the software, simply press the "Finish" button.



4.2 Connecting the Toxi Vision to the PC

To connect the Toxi Vision to the PC:

1. Plug the end of the connection cable with the 9-pin connector into your PC's communications port #1. If you are unable to locate your PC's communications port, see your PC's owner's manual.
2. Turn the Toxi Vision off.
3. Remove the six screws on the back of the Toxi Vision.
4. Remove the back cover plate. The internal connection port is located on the main board to the right of the alkaline batteries.

Note: Functional alkaline batteries must be installed in the Toxi Vision to change any available settings.

5. Plug the connector into the connection port on the main board.

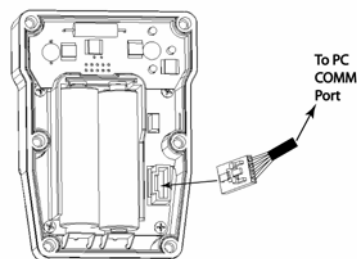

Figure 3.2 Connection diagram

4.3 Initializing the connection

Once the Toxi Vision is connected to the PC, double click on the Toxi Vision icon to run the PC software. The software may also be accessed through the Programs / Biosystems / ToxiVision file from the start menu.



Once the software has been activated, the following screen will be shown on the PC.



Once the PC has been connected to the Toxi Vision and the "No Connection"

screen is shown, press the Read button to initialize the connection.



Upon successful initialization, the following screen (or a similar one) will be shown:

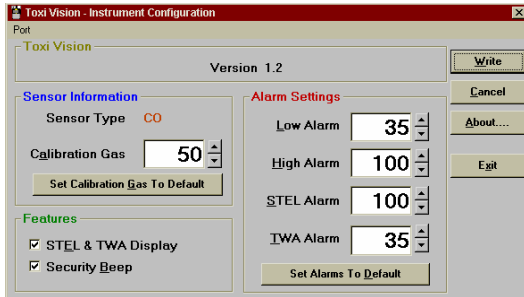

4.4 Calibration gas settings

Calibration gas information is contained in the Sensor Information panel in the left center section of the screen.

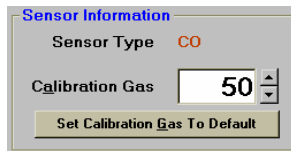

⚠WARNING Calibration values shown in the calibration value table must match those appearing on the calibration gas cylinder that will be used to calibrate the Toxi Vision. Non-matching calibration gas and calibration gas value settings may lead to inaccurate and potentially dangerous readings.

4.4.1 Change calibration gas settings

1. Connect and initialize the Toxi Vision to the PC as described in sections 4.2 and 4.3.
2. In the sensor information box, use the up and down arrows to adjust the calibration gas setting.

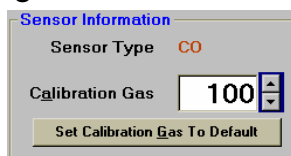

3. Once the appropriate adjustment is made on the PC, enter the new setting into the unit by pressing the

“Write” button at the upper right of the screen.

4.4.2 Restore default calibration gas settings

1. Press the “Set Calibration Gas Setting to Default” button, which is located at the bottom of the Sensor Information window. The default calibration gas setting will automatically be restored.
2. Enter the default setting into the unit by pressing the Write button at the upper right of the screen.

4.5 Features settings

The Toxi Vision’s PC software may be used to enable or disable instrument access to the STEL and TWA screens, and to enable or disable the security beep.

4.5.1 STEL and TWA display

User access to the STEL and TWA screens is controlled through the “STEL & TWA Display” checkbox in the features window.

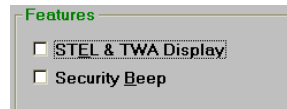

To change the setting, simply click on the checkbox.



To enter the new setting into the unit, press the Write button at the upper right of the screen.

4.5.2 Security Beep

The security beep setting is controlled through the “Security Beep” checkbox in the features window.



To change the setting, simply click on the checkbox.

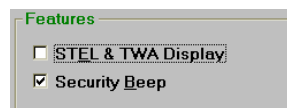

To enter the new setting into the unit, press the Write button at the upper right of the screen

4.6 Alarm settings

Access to the alarm settings is made through the Alarm Settings panel.

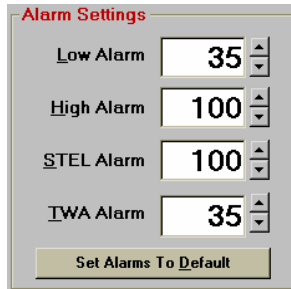

To change an alarm setting:

1. Connect the Toxi Vision to the PC as described in section 4.2.
2. Initialize the connection as described in section 4.3.
3. In the alarm settings information panel, use the up and down arrows to adjust the appropriate alarm setting.

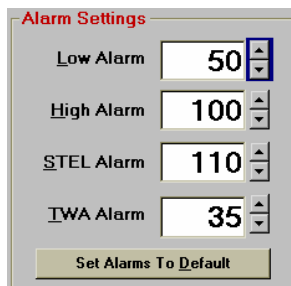

4. Once the appropriate adjustment is made on the PC, enter it into the unit by pressing the "Write" button at the upper right of the screen.

Caution: Do not set the TWA alarm to 0 PPM. The Toxi Vision includes a downscale alarm that is automatically set at -50% of the TWA value. If the TWA value is set to 0 PPM, then the downscale alarm will be activated at a reading of 0 PPM.

5. Maintenance

5.1 Replacing batteries

⚠WARNING Removal or replacement of alkaline batteries in potentially combustible atmospheres may lead to serious injury or death. The alkaline batteries used in the Toxi Vision may only be removed or replaced in an atmosphere that is known to be free of combustible gas.

To replace the batteries:

1. Remove the six screws on the back of the Toxi Vision.
2. Remove the back cover plate. The two AA alkaline batteries are located near the center of the main board.

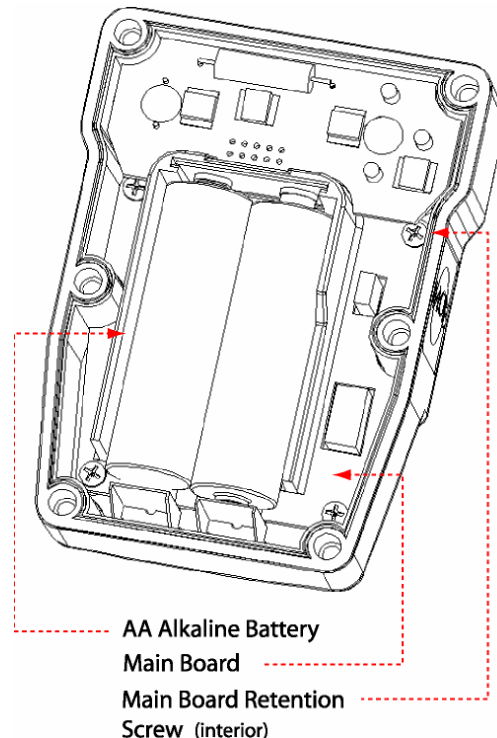

Figure 5.1: Interior view

3. Remove the old alkaline batteries and install new batteries. Be sure to align the polarity of the batteries in accordance with the diagram on the battery compartment.
4. Replace the back cover plate.
5. Reinstall the six screws on the back of the instrument that were removed in step 1.

⚠WARNING Use only Duracell MN1500 or Ultra MX1500, Eveready Energizer E91-LR6, Eveready EN91, Radio Shack 23-874* size AA 1.5V

Alkaline batteries, Eveready CH15* or Radio Shack 23-149* size AA NiMH batteries, or Eveready L91*† AA 1.5V Lithium batteries. Substitution of batteries may impair intrinsic safety.

*Not for use with ATEX certified instruments. (ATEX is a European safety directive).

†Not CSA approved (CSA is the Canadian Standards Association (similar to UL in the United States)).

5.2 Replacing sensors

The sensor in the Toxi Vision may require periodic replacement. To replace the sensor:

1. Loosen the six screws on the back of the Toxi Vision.
2. Remove the back cover.
3. Remove the batteries.
4. The sensor interface board is located in the top section of the instrument and can be removed by pulling it up from the main board.
5. Once the sensor interface board has been removed, gently remove the old sensor and install a new sensor of the same type.
6. Replace the sensor interface board. Be careful to properly align the connector pins, sensor and alarm gaskets before pressing the sensor interface board back into place.
7. Replace the batteries.

Note: Failure to immediately replace the alkaline batteries will significantly lengthen the stabilization period for toxic gas sensors.

8. Replace the back cover.
9. Retighten the six screws on the back of the instrument that were removed in step 1.

10. New sensors must be allowed to stabilize prior to use according to the following schedule. The detector must be powered off and functional batteries must be installed for the sensors to stabilize.

Sensor	Stabilization Period
Oxygen (O ₂)	1 hour
Toxic Gas	15 minutes

Note: The Toxi Vision must be calibrated after any sensor change. See section 3.5 and 3.6 above for details on the fresh air/zero and span calibration sequences.

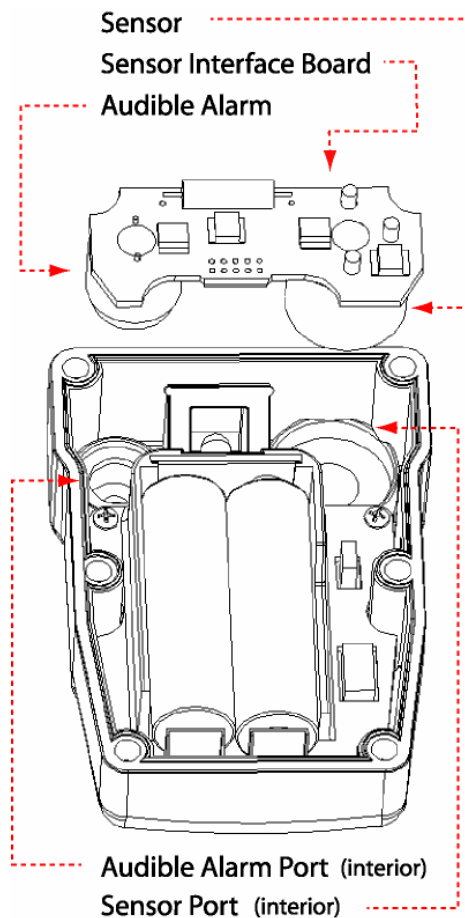

Figure 5.2 Interior view with sensor interface board removed

Replacement sensor list

Part No.	Sensor Description	Range	Resolution
54-39-90	O ₂ Oxygen (2 years)	0 – 30%/Vol.	0.1%
54-39-01	CO Carbon monoxide	0 – 1000 PPM	1 PPM
54-39-05	CO+ Dual purpose CO / H ₂ S Provides a non-specific readout for CO & H ₂ S	CO:0–1000 PPM H ₂ S:0 – 200 PPM	1 PPM
54-39-19	CO-H CO Minus, reduced sensitivity to H ₂	0 – 800 PPM	1 PPM
54-39-02	H ₂ S Hydrogen sulfide	0 – 200 PPM	1 PPM
54-39-03	SO ₂ Sulfur dioxide	0 – 100 PPM	0.1 PPM
54-39-21 [†]	NH ₃ Ammonia	0 – 100 PPM	1 PPM
54-39-08 [†]	Cl ₂ Chlorine (non-specific)	0 – 50 PPM	0.1 PPM
54-39-18 [†]	Cl ₂ Chlorine (specific)	0 – 50 PPM	0.1 PPM
54-39-12 [†]	ClO ₂ Chlorine dioxide (non-specific)	0 – 15 PPM	0.1 PPM
54-39-20 [†]	ClO ₂ Chlorine dioxide (specific)	0 – 5 PPM	0.01 PPM
54-39-09 [†]	NO ₂ Nitrogen dioxide sensor	0 – 50 PPM	0.1 PPM
54-39-10	HCN Hydrogen cyanide sensor	0 – 100 PPM	0.2 PPM
54-39-13	PH ₃ Phosphine sensor	0 – 10 PPM	0.01 PPM

Default toxic sensor calibration gas settings

Toxi Vision Part Number	Description	Default Calibration Gas Setting	Calibration Gas Part Number	
			58 or 103 Liter	34 Liter
54-37-01	CO Carbon monoxide	50 PPM CO	54-9033	54-9036
54-37-05	CO+ Dual purpose CO / H ₂ S	50 PPM CO	54-9033	54-9036
54-37-19	CO-H CO Minus	50 PPM CO	54-9033	54-9036
54-37-02	H ₂ S Hydrogen sulfide	25 PPM H ₂ S	54-9034	54-9057
54-37-03	SO ₂ Sulfur dioxide	10 PPM SO ₂	54-9037	54-9058
54-37-21	NH ₃ Ammonia	50 PPM NH ₃	54-9051	54-9061
54-37-08	Cl ₂ Chlorine (non-specific)	5 PPM Cl ₂	54-9052	54-9062
54-37-18	Cl ₂ Chlorine (specific)	5 PPM Cl ₂	54-9052	54-9062
54-37-12**	ClO ₂ Chlorine dioxide (non-specific)	1.7 PPM ClO ₂ **	54-9052	54-9062
54-37-20	ClO ₂ Chlorine dioxide(specific)	1 PPM ClO ₂	N/A	N/A
54-37-09	NO ₂ Nitrogen dioxide sensor	5 PPM NO ₂	54-9056	54-9059
54-37-10	HCN Hydrogen cyanide sensor	10 PPM HCN	54-9054	54-9074
54-37-13	PH ₃ Phosphine	5 PPM PH ₃	54-9065	54-9073

**Due to the 3.1 to 1 cross sensitivity of the ClO₂ (non-specific) sensor to chlorine (Cl₂), Sperian Instrumentation recommends calibrating the ClO₂ (non-specific) sensor with 5 PPM Cl₂ with the instrument's default calibration gas setting at 1.7 PPM ClO₂ (5 PPM/3.1=~1.7 PPM).

Exploded view and basic parts list

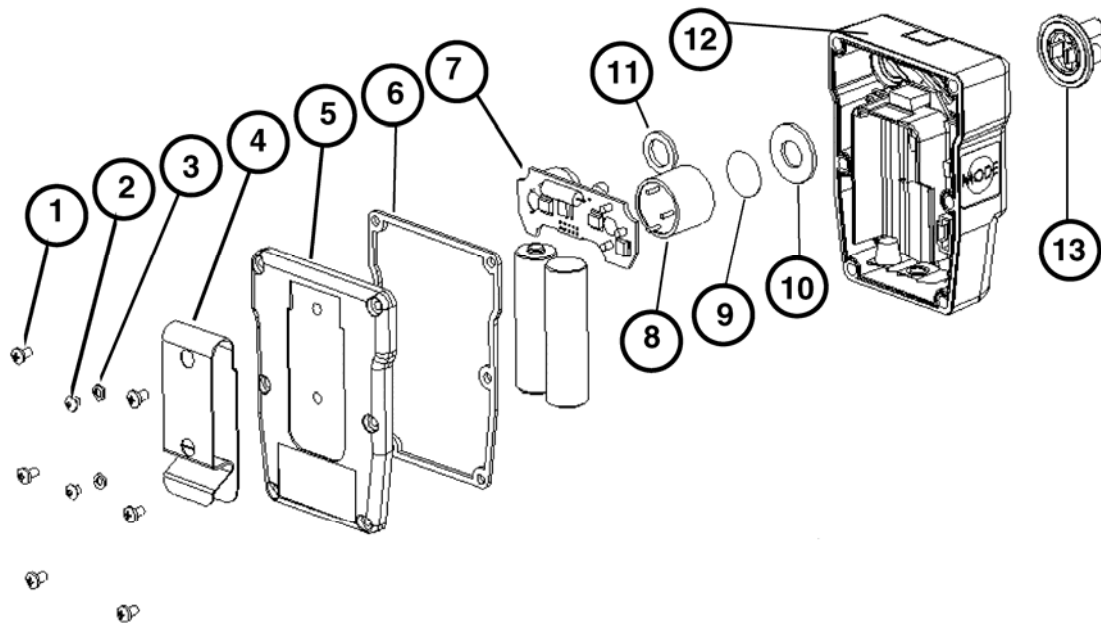

- | | | |
|-----|------------|---------------------------------|
| 1. | 05-1147(6) | Case retention screws |
| 2. | 05-1250(2) | Belt clip retention screws |
| 3. | 05-213(2) | Belt clip retention washers |
| 4. | 55-392(1) | Belt clip |
| 5. | 10-391(1) | Bottom housing |
| 6. | 34-063(1) | Main gasket |
| 7. | ** | Sensor interface board |
| 8. | ** | Sensor |
| 9. | ** | Sensor filter |
| 10. | 34-065(1) | Sensor gasket |
| 11. | 34-066(1) | Alarm gasket |
| 12. | 10-390(1) | Top housing |
| 13. | 54-38-01 | Calibration/sample draw adapter |
- ** Sensor interface board, sensor and sensor filter vary with instrument type.

Appendices

Appendix A: Sensor Cross-Sensitivity Chart

The table below provides the cross-sensitivity response of the Toxi Vision toxic gas sensors to common interference gases. The values are expressed as a percentage of the primary sensitivity, or the reading of the sensor when exposed to 100ppm of the interfering gas at 20°C. These values are approximate. The actual values depend on the age and condition of the sensor. Sensors should always be calibrated to the primary gas type. Cross-sensitive gases should not be used as sensor calibration surrogates without the express written consent of Sperian Instrumentation.

SENSOR	CO	H ₂ S	SO ₂	NO	NO ₂	Cl ₂	ClO ₂	H ₂	HCN	HCl	NH ₃	C ₂ H ₄	C ₂ H ₂
Carbon Monoxide (CO)	100	10	5	10	-15	-5	-15	50	15	3	0	75	250
Carbon Monoxide (CO+)	100	350	50	30	-60	-60	-120	50	n/d	n/d	0	75	250
Carbon Monoxide (CO-H)	100	10	5	n/d	(-)	(-)	(-)	5	n/d	n/d	n/d	(+)	(+)
Hydrogen Sulfide (H ₂ S)	0.5	100	20	2	-20	-20	-60	0.2	0	0	0	n/d	n/d
Sulfur Dioxide (SO ₂)	1	1	100	1	-100	-50	-150	0.2	n/d	n/d	0	(+)	(+)
Nitrogen Dioxide (NO ₂)	-5	-8	-1	0	100	90	270	0	n/d	n/d	0	n/d	n/d
Chlorine (Cl ₂) (nonspecific)	0	-3	-1	0	110	100	310	0	n/d	n/d	0	n/d	n/d
Chlorine (Cl ₂) (specific)	0	-3	0	n/d	12	100	0	0	0	2	n/d	0	0
Chlorine Dioxide (ClO ₂) (nonspecific)	0	-1	-0.3	0	40	33	100	0	n/d	n/d	0	n/d	n/d
Chlorine Dioxide (ClO ₂) (specific)	0	0	0	n/d	n/d	0	100	0	0	0	n/d	0	0
Ammonia (NH ₃) (54-39-21)	0	<5	0	n/d	0	0	n/d	0	0	0	100	0	0
Phosphine (PH ₃)	0.5	25	20	n/d	(-)	(-)	(-)	0.1	n/d	n/d	n/d	1	0.5
Hydrogen Cyanide (HCN)	0.5	350	160	-5	-100	-20	-60	0.1	100	65	-5	50	n/d

n/d = no data, (+) undetermined positive, (-) undetermined negative.

Appendix B Calibration Frequency Recommendation

One of the most common questions that we are asked at Sperian Instrumentation is: **“How often should I calibrate my gas detector?”**

Sensor Reliability and Accuracy

Today’s sensors are designed to provide years of reliable service. In fact, many sensors are designed so that with normal use they will only lose 5% of their sensitivity per year or 10% over a two-year period. Given this, it should be possible to use a sensor for up to two full years without significant loss of sensitivity.

Verification of Accuracy

With so many reasons why a sensor can lose sensitivity and given the fact that dependable sensors can be key to survival in a hazardous environment, frequent verification of sensor performance is paramount.

There is only one sure way to verify that a sensor can respond to the gas for which it is designed. That is to expose it to a known concentration of target gas and compare the reading with the concentration of the gas. This is referred to as a “bump” test. This test is very simple and takes only a few seconds to accomplish. **The safest course of action is to do a “bump” test prior to each day’s use.** It is not necessary to make a calibration adjustment if the readings fall between 90%* and 120% of the expected value. As an example, if a CO sensor is checked using a gas concentration of 50 PPM it is not necessary to perform a calibration unless the readings are either below 45 PPM or above 60 PPM.

***The Canadian Standards Association (CSA) requires the instrument to undergo calibration when the displayed value during a bump test fails to fall between 100% and 120% of the expected value for the gas.**

Lengthening the Intervals between Verification of Accuracy

We are often asked whether there are any circumstances in which the period between accuracy checks may be lengthened.

Sperian Instrumentation is not the only manufacturer to be asked this question! One of the professional organizations to which Sperian Instrumentation belongs is the Industrial Safety Equipment Association (ISEA). The “Instrument Products” group of this organization has been very active in developing a protocol to clarify the minimum conditions under which the interval between accuracy checks may be lengthened.

A number of leading gas detection equipment manufacturers have participated in the development of the ISEA guidelines concerning calibration frequency. Sperian Instrumentation’s procedures closely follow these guidelines.

If your operating procedures do not permit daily checking of the sensors, Sperian Instrumentation recommends the following procedure to establish a safe and prudent accuracy check schedule for your Sperian instruments:

1. During a period of initial use of at least 10 days in the intended atmosphere, check the sensor response daily to be sure there is nothing in the atmosphere that is poisoning the sensor(s). The period of initial use must be of sufficient duration to ensure that the sensors are exposed to all conditions that might have an adverse effect on the sensors.
2. If these tests demonstrate that it is not necessary to make adjustments, the time between checks may be lengthened. The interval between accuracy checking should not exceed 30 days.
3. When the interval has been extended the toxic and combustible gas sensors should be replaced immediately upon warranty expiration. This will minimize the risk of failure during the interval between sensor checks.
4. The history of the instrument response between verifications should be kept. Any conditions, incidents, experiences, or exposure to contaminants that might have an adverse effect on the calibration state of the sensors should trigger

immediate re-verification of accuracy before further use.

5. Any changes in the environment in which the instrument is being used, or changes in the work that is being performed, should trigger a resumption of daily checking.
6. If there is any doubt at any time as to the accuracy of the sensors, verify the accuracy of the sensors by exposing them to known concentration test gas before further use.

Gas detectors used for the detection of oxygen deficiencies, flammable gases and vapors, or toxic contaminants must be maintained and operated properly to do the job they were designed to do. Always follow the guidelines provided by the manufacturer for any gas detection equipment you use!

If there is any doubt regarding your gas detector’s accuracy, do an accuracy check! All it takes is a few moments to verify whether or not your instruments are safe to use.

One Button Auto Calibration

While it is only necessary to do a “bump” test to ensure that the sensors are working properly, all current Sperian gas detectors offer a one-button auto calibration feature. This feature allows you to calibrate a Sperian gas detector in about the same time as it takes to complete a “bump” test. The use of automatic bump test and calibration stations can further simplify the tasks, while automatically maintaining records.

Don’t take a chance with your life. Verify accuracy frequently!

Please read also Sperian Instrumentation’s application note: AN20010808 “Use of ‘equivalent’ calibration gas mixtures”. This application note provides procedures to ensure safe calibration of LEL sensors that are subject to silicone poisoning.

Sperian Instrumentation’s website is located at

<http://www.biosystems.com>

Sperian Instrumentation Warranty Gas Detection Products

General

Sperian Protection Instrumentation, LLC (hereafter Sperian) warrants gas detectors, sensors and accessories manufactured and sold by Sperian, to be free from defects in materials and workmanship for the periods listed in the tables below.

Damages to any Sperian products that result from abuse, alteration, power fluctuations including surges and lightning strikes, incorrect voltage settings, incorrect batteries, or repair procedures not made in accordance with the Instrument's Reference Manual are not covered by the Sperian warranty.

The obligation of Sperian under this warranty is limited to the repair or replacement of components deemed by the Sperian Instrument Service Department to have been defective under the scope of this standard warranty. To receive consideration for warranty repair or replacement procedures, products must be returned with transportation and shipping charges prepaid to Sperian at its manufacturing location in Middletown, Connecticut, or to a Sperian Authorized Warranty Service Center. It is necessary to obtain a return authorization number from Sperian prior to shipment.

THIS WARRANTY IS EXPRESSLY IN LIEU OF ANY AND ALL OTHER WARRANTIES AND REPRESENTATIONS, EXPRESS OR IMPLIED, INCLUDING BUT NOT LIMITED TO, THE WARRANTY OF FITNESS FOR A PARTICULAR PURPOSE. SPERIAN WILL NOT BE LIABLE FOR LOSS OR DAMAGE OF ANY KIND CONNECTED TO THE USE OF ITS PRODUCTS OR FAILURE OF ITS PRODUCTS TO FUNCTION OR OPERATE PROPERLY.

Instrument & Accessory Warranty Periods

Product(s)	Warranty Period
PhD ⁵ , PhD Lite, PhD Plus, PhD Ultra, Cannonball3, MultiVision, Toxi, Toxi/Oxy Plus, Toxi/Oxy Ultra, ToxiVision, Ex Chek	As long as the instrument is in service
ToxiPro [®] , MultiPro	2 years from date of purchase
ToxiLtd [®]	2 years after activation or 2 years after the "Must Be Activated By" date, whichever comes first
Toxi3Ltd [®]	3 years after activation or 3 years after the "Must Be Activated By" date, whichever comes first
Mighty-Tox	90 days after activation or 90 days after the "Must Be Activated By" date, whichever comes first
Mighty-Tox 2 Prorated credit is given towards repair or purchase of a new unit of the same type.	0 – 6 months of use 100% credit 6 – 12 months of use 75% credit 12 – 18 months of use 50% credit 18 – 24 months of use 25% credit
IQ Systems, Series 3000, Airpanel, Travelpanel, ZoneGuard, Gas✓Chek1 and Gas✓Chek4	One year from the date of purchase
Battery packs and chargers, sampling pumps and other components, which by their design are consumed or depleted during normal operation, or which may require periodic replacement	One year from the date of purchase

Sensor Warranty Periods

Instrument(s)	Sensor Type(s)	Warranty Period
PhD Plus, PhD Ultra, PhD ⁵ , PhD Lite, Cannonball3, MultiVision, MultiPro, ToxiVision, ToxiPro [®] , Ex Chek	O ₂ , LEL**, CO, CO+, H ₂ S & Duo-Tox	2 Years
	All Other Sensors	1 Year
Toxi, Toxi/Oxy Plus, Toxi/Oxy Ultra	CO, CO+, H ₂ S	2 Years
	All Other Sensors	1 Year
All Others	All Sensors	1 Year

** Damage to combustible gas sensors by acute or chronic exposure to known sensor poisons such as volatile lead (aviation gasoline additive), hydride gases such as phosphine, and volatile silicone gases emitted from silicone caulks/sealants, silicone rubber molded products, laboratory glassware greases, spray lubricants, heat transfer fluids, waxes & polishing compounds (neat or spray aerosols), mold release agents for plastics injection molding operations, waterproofing formulations, vinyl & leather preservatives, and hand lotions which may contain ingredients listed as cyclomethicone, dimethicone and polymethicone (at the discretion of Sperian's Instrument Service department) void Sperian Instrumentation's Standard Warranty as it applies to the replacement of combustible gas sensors.

Toxi Vision

Type	O ₂	H ₂ S	SO ₂
	CO	CO-H	CO+
	NH ₃	Cl ₂	ClO ₂
	NO ₂	HCN	PH ₃

Software Version _____

Vibrating Alarm

Serial Number _____

MFG Date ____/____/____