



**Toxi Vision IR CO<sub>2</sub>**

**Single Gas  
Detector**

**Reference Manual**



**Sperian Instrumentation  
651 South Main Street  
Middletown, CT 06457  
(800) 711-6776  
(860) 344-1079  
Fax (860) 344-1068  
Part number 13-313  
Version 1.11  
5DEC2008**

# **WARNING**

**THE TOXI VISION IR CO<sub>2</sub> PERSONAL PORTABLE GAS DETECTORS HAVE BEEN DESIGNED FOR THE DETECTION AND MEASUREMENT OF POTENTIALLY HAZARDOUS ATMOSPHERIC CONDITIONS.**

**IN ORDER TO ASSURE THAT THE USER IS PROPERLY WARNED OF POTENTIALLY DANGEROUS ATMOSPHERIC CONDITIONS, IT IS ESSENTIAL THAT THE INSTRUCTIONS IN THIS REFERENCE MANUAL BE READ, FULLY UNDERSTOOD, AND FOLLOWED.**

**Toxi Vision IR CO<sub>2</sub> Reference Manual  
Sperian Part Number 13-313  
Version 1.11  
Copyright 2008**

**Sperian Protection Instrumentation, LLC  
Middletown, Connecticut 06457**

**All rights reserved.**

**No page or part of this operation manual may be reproduced in any form without written permission of the copyright owner shown above.**

**Sperian reserves the right to correct typographical errors.**

# Table of Contents

<b>Certifications</b> .....	<b>3</b>
<b>ATEX Label Requirement</b> .....	<b>3</b>
<b>Warnings and Cautions</b> .....	<b>3</b>
A. Signal Words.....	3
B. Warnings.....	4
<b>1. Overview</b> .....	<b>5</b>
1.1 Methods of sampling.....	5
1.2 IR CO <sub>2</sub> Sensors.....	5
1.3 Alarm logic .....	5
1.3.1 Gas alarms .....	5
1.3.2 Battery alarms.....	5
1.3.3 Missing sensor alarm.....	6
1.3.4 Optional vibrating alarm.....	6
1.4 Calibration .....	6
1.5 PC Communications .....	6
1.6 Features .....	6
1.6.1 Security beep.....	6
1.6.2 Latching danger alarm.....	6
1.6.3 Calibration due warnings.....	6
1.7 Data storage.....	6
1.7.1 Black box datalogger .....	6
1.7.2 Event logger.....	7
1.8 Design components .....	7
1.9 Standard accessories .....	8
1.10 Toxi Vision IR CO <sub>2</sub> Kits .....	8
<b>2. Instrument Functions</b> .....	<b>8</b>
2.1 Turning the Toxi Vision IR CO <sub>2</sub> on.....	8
2.2 Backlight.....	9
2.3 View MAX reading .....	9
2.4 View STEL and TWA readings.....	9
2.5 Turning the Toxi Vision IR off .....	9
2.6 Sampling.....	9
2.6.1 Sample draw kit usage .....	10
2.7 Error Messages.....	10
<b>3. Calibration</b> .....	<b>10</b>
3.1 Verification of accuracy.....	10
3.2 Response (bump) testing.....	11
3.3 Calibration .....	11
3.3.1 Zero Calibration .....	11
3.3.2 Span Calibration .....	12
3.4 Failure to calibrate .....	13
3.4.1 Zero calibration failure.....	13
3.4.2 Span calibration failure.....	13
3.5 Forced zero calibration .....	14

<b>4. Maintenance .....</b>	<b>14</b>
4.1 Replacing alkaline batteries .....	14
4.2 Charging NiMH batteries .....	14
4.3 Replacing sensors .....	15
<b>5. Direct programming.....</b>	<b>15</b>
5.1 MAX on or off .....	16
<b>Exploded View .....</b>	<b>17</b>
<b>Appendix A: Calibration Frequency Recommendation.....</b>	<b>18</b>
<b>Sperian Instrumentation Toxi Vision IR CO<sub>2</sub> Standard Warranty .....</b>	<b>19</b>

## Certifications

UL Class I, Division 1, Groups A, B, C, D

NEPSI (China) Ex d ia IIC T4

ATEX: 07 ATEX 0616084

Ex d ia IIC T4

IECEX: IECEX UL 07.0006

## ATEX Label Requirement

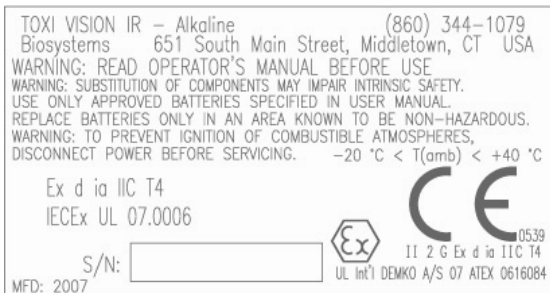

## Warnings and Cautions

### A. Signal Words

The following signal words, as defined by ANSI Z535.4-1998, are used in the Toxi Vision IR CO<sub>2</sub> Operator's Guide.

**⚠ DANGER** indicates an imminently hazardous situation which, if not avoided, will result in death or serious injury.

**⚠ WARNING** indicates a potentially hazardous situation which, if not avoided, could result in death or serious injury.

**⚠ CAUTION** indicates a potentially hazardous situation, which if not avoided, may result in moderate or minor injury.

**CAUTION** used without the safety alert symbol indicates a potentially hazardous situation which, if not avoided, may result in property damage.

## B. Warnings

1. **⚠️WARNING** The Toxi Vision IR CO<sub>2</sub> personal, portable gas detector has been designed to detect accumulations of carbon dioxide. An alarm condition indicates the presence of a potentially life-threatening hazard and should be taken very seriously.
2. **⚠️WARNING** In the event of an alarm condition it is important to follow established procedures. The safest course of action is to immediately leave the affected area, and to return only after further testing determines that the area is once again safe for entry. Failure to immediately leave the area may result in serious injury or death.
3. **⚠️WARNING** Use only Duracell MN1500 or Ultra MX1500, Eveready Energizer E91-LR6, or Eveready Energizer EN91 size AA 1.5V alkaline batteries. Substitution of batteries may impair intrinsic safety.
4. **⚠️WARNING** To reduce the risk of explosion, do not mix old or used batteries with new batteries and do not mix batteries from different manufacturers.
5. **⚠️WARNING** The accuracy of Toxi Vision IR CO<sub>2</sub> instruments should be checked periodically with known concentration calibration gas. Failure to check accuracy can lead to inaccurate and potentially dangerous readings.
6. **⚠️WARNING** A sensor that cannot be calibrated or is found to be out of tolerance must be replaced immediately. An instrument that fails calibration may not be used until testing with known concentration test gas determines that accuracy has been restored, and the instrument is once again fit for use.
7. **⚠️WARNING** Do not reset the calibration gas concentration setpoint in the Toxi Vision IR CO<sub>2</sub> unless the concentration of your calibration gas differs from the concentration of the calibration gas that is normally supplied by Sperian Instrumentation for use in calibrating the Toxi Vision IR CO<sub>2</sub>.
8. **⚠️WARNING** Use of non-standard calibration gas and/or calibration kit components when calibrating the Toxi Vision IR CO<sub>2</sub> can lead to dangerously inaccurate readings and may void the standard Sperian Instrumentation warranty. Sperian Instrumentation offers calibration kits and long-lasting cylinders of test gas specifically developed for easy calibration. Customers are strongly urged to use only Sperian calibration materials when calibrating the Toxi Vision IR CO<sub>2</sub>.
9. **⚠️WARNING** Substitution of components may impair intrinsic safety.
10. **⚠️WARNING** For safety reasons the Toxi Vision IR CO<sub>2</sub> must be operated by qualified personnel only. Read, understand and follow the directions set forth in this reference manual before operating the Toxi Vision IR CO<sub>2</sub>.
11. **⚠️WARNING** The Toxi Vision IR CO<sub>2</sub> has been tested for intrinsic safety in Explosive Gas/AIR (21.0% O<sub>2</sub>) Only.

## 1. Overview

The Toxi Vision IR CO<sub>2</sub> is a single sensor gas detector designed to detect carbon dioxide (CO<sub>2</sub>).

Carbon dioxide is a colorless gas that occurs naturally in the atmosphere. Carbon dioxide levels between 100 PPM and 1000 PPM are considered normal in fresh air and are typically the result of natural processes including the respiration of aerobic organisms, the combustion of organic matter and volcanic outgassing. High levels of carbon dioxide are considered hazardous to humans.

Both NIOSH and OSHA have formal exposure limits for carbon dioxide. Both organizations recognize a TWA (Time Weighted Average) maximum of 5,000 PPM (0.5% vol.) and a STEL (Short Term Exposure Limit) of 30,000 PPM (3.0% vol.) for any 15 minute period. NIOSH also recognizes an IDLH level at 40,000 PPM (4.0% vol.).

The Toxi Vision IR CO<sub>2</sub> includes numerous features designed to meet specific user requirements. This chapter will broadly discuss the use and capabilities of the Toxi Vision IR CO<sub>2</sub>.

### 1.1 Methods of sampling

The Toxi Vision IR CO<sub>2</sub> may be used in either diffusion or sample-draw mode. In either mode, the gas sample must enter the sensor compartment for the instrument to register a gas reading.

In diffusion mode, the atmosphere reaches the sensor by diffusing through the sensor port on the front of the instrument. Normal air movements are enough to carry the sample to the sensor. The sensor reacts quickly to changes in the concentration of the gas being measured.

It is also possible to use the Toxi Vision IR CO<sub>2</sub> to sample remote locations with the hand-aspirated sample-draw kit that is available separately. During remote sampling, the gas sample is drawn into the sensor compartment through the probe assembly and a length of tubing.

### 1.2 IR CO<sub>2</sub> Sensors

The ToxiVision IR uses an infrared sensor to determine the amount of the target gas in the atmosphere. Inside the sensor infrared light is passed through the gas sample into a prism that allows the light's

intensity at specific wavelengths to be measured. The intensity of the light in the prism at a certain wavelength varies with the amount of CO<sub>2</sub> present in the atmosphere. The detector reads the intensity of the light in the prism at the known wavelength and converts it into a gas reading.

## 1.3 Alarm logic

### 1.3.1 Gas alarms

Toxi Vision IR CO<sub>2</sub> gas alarms are user-adjustable and may be set anywhere within the sensor range. When an alarm set point is exceeded the loud multi-tone audible alarm sounds, and the bright red LED alarm light flashes.

All Toxi Vision IR CO<sub>2</sub> instruments are shipped with default Warning and Danger alarms enabled. Adjustable STEL and TWA alarms can be enabled by the user as needed.

### 1.3.2 Battery alarms

The Toxi Vision IR CO<sub>2</sub> is equipped with a three stage low battery alarm.

When battery voltage is reduced to the point where there is approximately one hour of battery life remaining, the battery icon will be displayed on the LCD.



When battery voltage is reduced to the point where this is approximately 15 minutes of battery life remaining, the battery and warning icons will be displayed on the LCD.



If the battery voltage is reduced to the point where the battery can no longer power the instrument, the instrument will go into a high alarm while displaying "OFF" on the screen as long as it can or until the MODE button is pressed to turn the instrument off.



### 1.3.3 Missing sensor alarm

If the Toxi Vision IR CO<sub>2</sub> determines that the sensor is missing, the instrument will go into alarm and indicate F1 on the screen with the warning symbol.

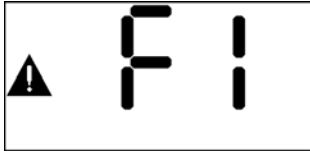

See section 2.7 for a full list of error messages.

### 1.3.4 Optional vibrating alarm

A vibrating alarm is available as an option for instruments that will be used in high noise areas.

## 1.4 Calibration

The Toxi Vision IR CO<sub>2</sub> features one-button zero and span calibration functions.

**Calibration procedures are discussed in detail in chapter 3.**

## 1.5 PC Communications

The Toxi Vision IR CO<sub>2</sub> features a built-in IrDA port for communications between a PC and the instrument. The IrDA port is located below the alarm LED. See figure 1.8 below.

## 1.6 Features

### 1.6.1 Security beep

The Toxi Vision IR CO<sub>2</sub> includes a security beep that can be enabled or disabled according to the needs of the user. At the default interval, the Toxi Vision IR CO<sub>2</sub> will emit a beep every 60 seconds to remind the user that the instrument is active.

### 1.6.2 Latching danger alarm

The Toxi Vision IR CO<sub>2</sub> includes a latching danger alarm that can be enabled or disabled according to the needs of the user.

With the latching alarm enabled, once the Toxi Vision IR CO<sub>2</sub> enters a danger alarm, it will remain in alarm even after the readings have dropped back below the danger alarm threshold. To acknowledge the alarm and return to normal operation, press the MODE button.

With the latching alarm disabled, user intervention is not required following a danger alarm. The Toxi Vision IR CO<sub>2</sub> will automatically return to normal operation

and the alarms will cease as soon as the reading drops below the danger alarm threshold.

### 1.6.3 Calibration due warnings

The Toxi Vision IR CO<sub>2</sub> includes optional calibration due warnings. The calibration due warning option is disabled at the factory, but can be enabled with BioTrak software for any period between 1 and 180 days. Upon instrument startup, if the calibration due warning is enabled and the instrument is due for calibration, the Toxi Vision IR will show “cal due” in the startup screens. If the instrument is due for zero calibration, the triangular warning symbol will be shown with the “cal due” message and will then be shown on the current gas readings screen. If the instrument is due for span calibration, the triangular warning symbol and the calibration bottle icon will be shown with the “cal due” message and both symbols will then be shown on the current gas readings screen.

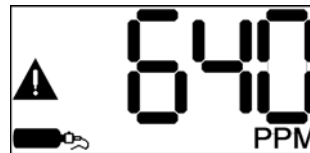

## 1.7 Data storage

Alkaline versions of the Toxi Vision IR CO<sub>2</sub> come equipped with an Event Logger as standard equipment.

Rechargeable versions of the Toxi Vision IR CO<sub>2</sub> come equipped with the Event Logger and a Black Box Datalogger as standard equipment. The rechargeable version of the Toxi Vision IR CO<sub>2</sub> may also be purchased with a fully enabled datalogger.

The upgrades necessary to convert the Black Box Datalogger into a fully enabled datalogger must be performed at the Sperian Instrumentation factory. Call Sperian Instrumentation for details.

**Note: Sperian Instrumentation's BioTrak software is used to extract and view data from the Toxi Vision IR CO<sub>2</sub>.**

### 1.7.1 Black box datalogger

A black box data recorder is a standard feature in the rechargeable versions of the Toxi Vision IR CO<sub>2</sub>. The “black box” is continually in operation whether the user is aware of it or not. The black box stores important information such as gas

readings, turn-on times, turn-off times, temperatures, battery conditions, the most recent calibration date and settings, type of sensor currently installed, sensor serial number, warranty expiration and service due dates, and current alarm settings.

There is a finite amount of memory storage available in the black box data recorder. Once the memory is “full”, the Toxi Vision IR CO<sub>2</sub> will begin to write the new data over the oldest data. The black box data recorder will store approximately 40 hours of data in one-minute increments before it begins to write new data over the oldest data. In this way, the newest data is always conserved.

To extract the information from the black box data recorder, the Toxi Vision IR CO<sub>2</sub> must be returned to Sperian Instrumentation. Once the data is downloaded from the instrument, a report will be generated. The unit and the report will then be returned to the user. Simply call Sperian Instrumentation’s Instrument Service Department to obtain a return authorization number. There is no charge for the downloading service, but the user is responsible for any freight charges incurred.

### 1.7.2 Event logger

An event logger is a standard feature on all versions of the Toxi Vision IR CO<sub>2</sub>. The event logger stores data associated with alarm conditions. Each (alarm) event includes the following data for each of the installed sensors: Sensor type, max reading, average reading, start time, end time and duration of the event. The Toxi Vision IR CO<sub>2</sub> stores the 20 most recent events. Once 20 events have been stored, the Toxi Vision IR CO<sub>2</sub> will begin to systematically overwrite the data from the oldest event in memory with data from new events. One event may be a combination of different alarms occurring simultaneously or in immediate succession. The event logger may be downloaded using s’ BioTrak software. The PC must be equipped with IrDA to provide a connection.

## 1.8 Design components

**1. Case:** The instrument is enclosed in a solid, metal-plated ABS case. A black EPDM gasket between the upper and

lower sections of the case protects against leakage or exposure to liquids.

- 2. Front face:** The front face of the instrument houses the graphics capable LCD display, sensor port, LED alarm, IrDA port and audible alarm port.
- 3. LCD display:** The liquid crystal display (LCD) allows display of gas readings, messages and other information. A built-in backlight allows the display to be read even in low light conditions.
- 4. Alarm light (LED)** A bright red LED (light-emitting diode) alarm light provides a visual indication of the alarm state. The light is visible from the front and top of the instrument.
- 5. IrDA Port:** The IrDA port is located under the LED alarm light and is used to communicate with a PC.

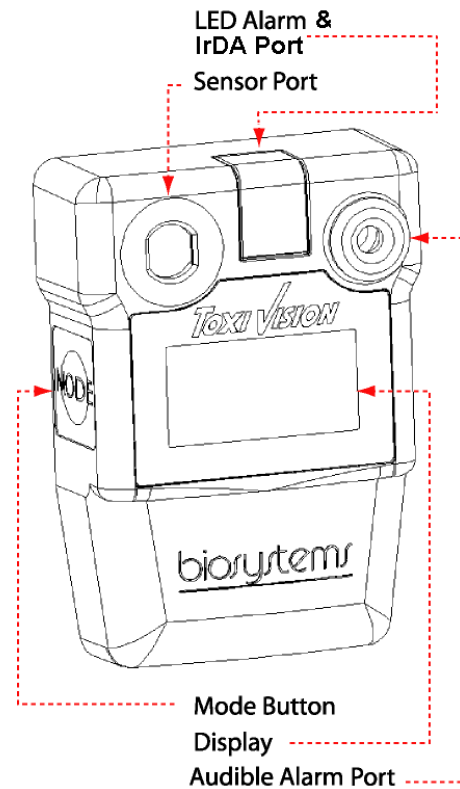

**Figure 1.8 Exterior front view.**

- 6. MODE button:** The large push-button on the left side of the instrument is called the MODE button. The MODE button is used to turn the Toxi Vision IR CO<sub>2</sub> on and off, to turn on the backlight, to view the MAX screen and to access the automatic calibration sequences.

7. **Audible alarm orifice:** A cylindrical resonating chamber contains the loud audible alarm.
8. **Sensor port:** The IR sensor is located just below the sensor port at the upper left corner of the instrument.
9. **Bottom surface:** The belt clip attaches to the bottom surface of the instrument.

### 1.9 Standard accessories

Standard accessories with every Toxi Vision IR CO<sub>2</sub> include installed sensor, reference manual, quick reference card and calibration/sample draw adapter.

Alkaline versions include a set of 2 AA alkaline batteries.

Rechargeable versions include the built-in rechargeable NiMH battery and charger.

Optional accessories include manual (hand-aspirated) sample draw kit, PC software kit, and rubber boot.

Toxi Vision IR CO<sub>2</sub> instruments that are not ordered in a complete kit are delivered in a cardboard box.

### 1.10 Toxi Vision IR CO<sub>2</sub> Kits

The Toxi Vision IR CO<sub>2</sub> can be purchased as part of a complete kit that includes everything needed to calibrate the instrument and operate the instrument in diffusion mode.

## 2. Instrument Functions

Field operation of the Toxi Vision IR CO<sub>2</sub> is controlled entirely through the MODE button, which is located on the left side of the instrument.

The MODE button is used to turn the Toxi Vision IR CO<sub>2</sub> on and off, to turn on the backlight, to access MAX gas readings for the current session and to initiate the zero and span calibration functions.

**Note: The ToxiVision IR CO<sub>2</sub> will display in either PPM or %Volume depending on the intensity of the CO<sub>2</sub> reading. When the instrument reading reaches 10,000PPM it will change over to a %Volume reading of 1.0%Vol.**

**10,000PPM = 1.0%/Volume**

### 2.1 Turning the Toxi Vision IR CO<sub>2</sub> on

Press and hold the MODE button until the following display test screen is shown, then release the MODE button.

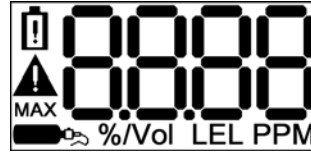

At start-up, the Toxi Vision IR CO<sub>2</sub> will automatically go through a basic electronic self-test and start-up sequence that will take approximately sixty seconds. During the self-test sequence, the display backlight will momentarily turn on. Then the instrument will run through the following screens. The software versions and sensor type will be shown. If the instrument is equipped with a fully enabled datalogger, "dL" will be shown.

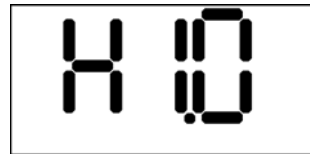

The warning alarm level (indicated by Lo) will then be displayed, followed by the danger alarm level (indicated by Hi). The instrument will also test the low and high audible alarms.



↑ Alternate 3 times ↓



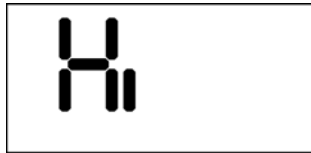

↑ Alternate 3 times ↓

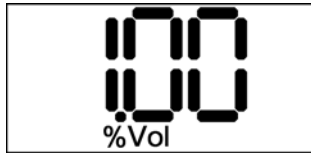

**Note: When the Toxi Vision IR CO<sub>2</sub> reaches 10,000PPM, the measurement will be given in percent by volume.**

**10,000 PPM = 1.00%/Volume**

In rechargeable versions, if the calibration due warning is enabled and the Toxi Vision IR CO<sub>2</sub> is due for calibration “cal” “due” will be shown. If the triangular warning symbol alone is shown, then the instrument is due for zero calibration. If the triangular warning symbol and the bottle icon are shown then the instrument is due for span calibration.

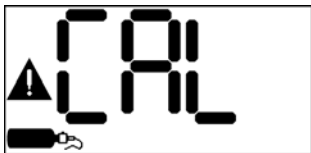

↓



The instrument will then proceed with a thirty second warm up cycle.



At the end of the warm up cycle the current CO<sub>2</sub> reading will be displayed.



## 2.2 Backlight

The Toxi Vision IR CO<sub>2</sub> includes a backlight that is automatically turned on during an alarm condition. The backlight can also be manually activated while the current gas reading is displayed by pressing the MODE

button once. The backlight will automatically turn itself off in about twenty seconds.

## 2.3 View MAX reading

From the current gas reading screen, press the MODE button once to activate the backlight and then once more to view the MAX value screen. The MAX value represents the peak reading recorded by the instrument during the current operating session.



## 2.4 View STEL and TWA readings

If the STEL and TWA alarm functions are enabled, the computed values can be viewed by pressing the MODE Button when the MAX reading screen is shown. STEL values are shown first. Press MODE again to view the TWA values. STEL and TWA values are computed automatically by the ToxiVision IR CO<sub>2</sub> when these functions are enabled in the instrument.

**See section 5 for direct programming options.**

## 2.5 Turning the Toxi Vision IR off

To turn the Toxi Vision IR CO<sub>2</sub> off, press and hold the MODE button down until the instrument beeps three times and OFF is displayed.



Once OFF is displayed, release the MODE button. The instrument has been successfully turned off when the display goes blank.

## 2.6 Sampling

The Toxi Vision IR CO<sub>2</sub> may be used in either diffusion or sample-draw mode. In either mode, the gas sample must enter the sensor compartment for the instrument to register a gas reading.

In diffusion mode, the atmosphere reaches the sensor by diffusing through the sensor port on the front of the instrument. Normal

air movements are enough to carry the sample to the sensor. The sensor reacts quickly to changes in the concentration of the gas being measured.

It is also possible to use the Toxi Vision IR CO<sub>2</sub> to sample remote locations with the hand-aspirated sample-draw kit that is available separately. During remote sampling, the gas sample is drawn into the sensor compartment through the probe assembly and a length of tubing.

### 2.6.1 Sample draw kit usage

1. Connect the end of the hose that is closer to the squeeze bulb to the sample draw adapter. Then connect the other end of the hose to the sample probe.
2. Attach the sample draw adapter to the Toxi Vision IR CO<sub>2</sub>.
3. Cover the end of the sample draw probe assembly with a finger, and squeeze the aspirator bulb. If there are no leaks in the sample draw kit components, the bulb should stay deflated for a few seconds.
4. Insert the end of the sample probe into the location to be sampled.
5. Squeeze the aspirator bulb several times to draw the sample from the remote location to the sensor compartment. Allow one squeeze of the bulb for every one foot of sampling hose for the sample to reach the sensors. Continue to squeeze the bulb for an additional 45 seconds or until readings stabilize.
6. Note the gas measurement readings.

**CAUTION: Hand aspirated remote sampling only provides continuous gas readings for the area in which the probe is located when the bulb is being continuously squeezed.**

**Note: Each time a reading is desired, it is necessary to squeeze the bulb a sufficient number of times to bring a fresh sample to the sensor compartment.**

### 2.7 Error Messages

The ToxiVision IR microprocessor monitors the instrument continuously. When a problem is found the instrument will show an error message.

Error #	Detail
F 1	No Sensor Installed
F 2	Bad Unit data read from flash / Unit will re-initialize
F 3	Bad Sensor data read from flash / Sensor data will re-initialize
F 4	Bad Flash memory erase / Unit turns off and will not turn back on again
F 5	Bad Flash memory write
F 6	No vibrator installed / Vibrator installed and not working

**If an error message is shown, stop using the detector and contact Sperian Instrumentation or you local distributor for further information.**

## 3. Calibration

The Toxi Vision IR CO<sub>2</sub> features fully automated zero and span calibration functions. The MODE button is used to initiate the automatic calibration sequence. Calibration adjustments are made automatically by the instrument.

### 3.1 Verification of accuracy

Calibration of the Toxi Vision IR CO<sub>2</sub> is a two step procedure.

Unlike many gas detectors, the Toxi Vision IR CO<sub>2</sub> requires two different gas sources to fully calibrate the instrument. The reason for this is that it is effectively impossible to zero calibrate a CO<sub>2</sub> detector in fresh air because there is an unknown and varying amount of background CO<sub>2</sub> present in the atmosphere.

**Step one** is to expose the Toxi Vision IR CO<sub>2</sub> to a known source of calibration gas that contains 0 PPM CO<sub>2</sub>. If the reading shows anything other than 0 PPM, then the instrument must be zero calibrated as discussed below in section 3.3.

**Step two** is to make sure the CO<sub>2</sub> sensor is accurate by exposing it to a test gas of known concentration and noting the sensor response. The reading is considered to be accurate when the displayed value falls between 90% and 120% of the expected value for the gas being used. If readings are considered accurate, there is no need to adjust your gas detector. If the readings are inaccurate, the instrument must be span calibrated before further use as discussed in section 3.4.

**⚠WARNING Accuracy of the Toxi Vision IR CO<sub>2</sub> should be checked periodically with known concentration calibration gas. Failure to check**

accuracy can lead to inaccurate and potentially dangerous readings.

### 3.2 Response (bump) testing

The accuracy of the Toxi Vision IR CO<sub>2</sub> as it responds to calibration gas containing CO<sub>2</sub> may be verified at any time by a simple functional (bump) test.

To perform a response (bump) test, do the following:

1. Turn the Toxi Vision IR CO<sub>2</sub> on and allow the instrument to complete the warm up period.
2. Make sure the instrument is located in fresh air.
3. Verify that the current gas readings match the concentrations present in fresh air. Any reading above 100 PPM and below 1000PPM is OK. Be careful not to breathe on the instrument. Breath contains levels of CO<sub>2</sub> that easily exceed 1000PPM.
4. Apply calibration gas containing a known amount of CO<sub>2</sub> as shown below in figure 3.2.
5. Wait for the readings to stabilize. (Forty-five seconds to one minute is usually sufficient.)
6. Note the readings. Readings are considered accurate if they are between 90% and 120% of the expected reading. If the readings are considered accurate, then the instrument may be used without further adjustment.

**For further instructions on calibration frequency recommendations and a more detailed explanation of accuracy requirements, see Appendix A.**

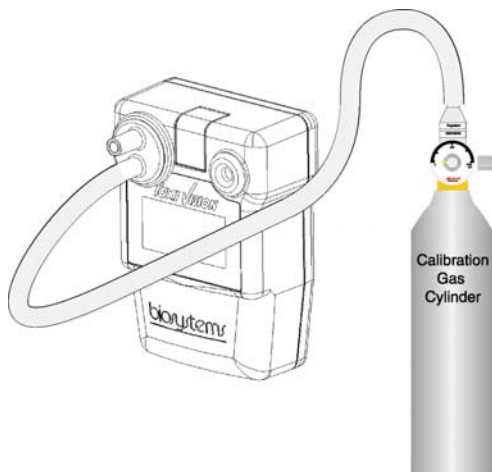

**Figure 3.2: Proper bump-test/span calibration set-up**

**Note: If gas concentration readings do not fall between 90% and 120% of the expected values during a functional (bump) test, the instrument must be adjusted using the calibration procedures discussed in section 3.3 before further use.**

### 3.3 Calibration

Calibration of the ToxiVision IR must be done with two cylinders of calibration gas; one containing 0 PPM CO<sub>2</sub> and one containing a known quantity of CO<sub>2</sub> (2.00% volume CO<sub>2</sub> is standard).

**Note: The Zero Calibration in the Toxi Vision IR CO<sub>2</sub> cannot be performed with fresh air as the calibration source due to the fact that fresh air contains a varying amount of CO<sub>2</sub>. A cylinder of calibration gas containing 0 PPM CO<sub>2</sub> is required.**

#### 3.3.1 Zero Calibration

To initiate the calibration procedure:

1. Connect the cylinder of calibration gas containing 0 PPM CO<sub>2</sub> to the ToxiVision IR CO<sub>2</sub> as shown above in figure 3.2 and flow gas to the instrument for about 30 seconds until the reading stabilizes.
2. From the current gas reading screen, press the MODE button three times within two seconds to begin the fresh air/zero calibration sequence. The Toxi Vision IR will briefly display "CAL" and then begin a 5 second countdown.



Following "CAL", the instrument will show the following screens to indicate that calibration gas containing 0 PPM CO<sub>2</sub> is required to calibrate the Toxi Vision IR CO<sub>2</sub>.



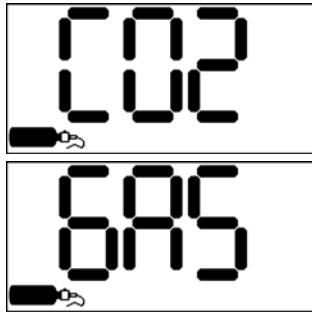

3. Press the MODE button. The Toxi Vision IR CO<sub>2</sub> will briefly display “CAL” and then begin a 5 second countdown.



4. Press the MODE button before the end of the 5-second countdown to begin the zero calibration. The zero calibration has been successfully initiated when the Toxi Vision IR CO<sub>2</sub> alternates between the following two screens:



↑ Alternating ↓



5. Once the zero calibration is complete, the instrument will begin another 5-second countdown for the span calibration.

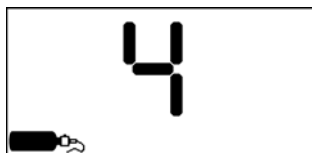

6. If span calibration is not required, allow the countdown to reach 0 without pressing the MODE button. Then disconnect calibration materials from the instrument.
7. For span calibration press the MODE button prior to the end of the countdown and proceed to section 3.3.2 for further instructions.

### 3.3.2 Span Calibration

To perform a span calibration, first perform a zero calibration as discussed above in

section 3.3.1. After successful completion of the zero calibration, the instrument will begin a second five-second countdown with the calibration gas bottle icon highlighted.

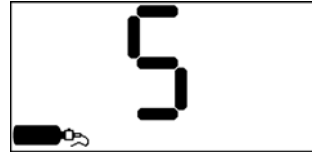

1. Press the MODE button before the countdown is complete to initiate the span calibration. The display will alternate between “GAS” and the expected concentration of calibration gas in terms of percent by volume (%Vol).



↑ Alternating ↓



2. Apply calibration gas as shown above in figure 3.2. Once calibration gas is detected, the readout will change to show the gas reading.



Once the reading reaches 10,000 PPM, the display will change over to percent by volume (%Vol).

**10,000PPM = 1.0%/Volume**

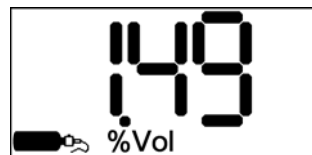

3. The calibration is fully automatic from this point on. Once the instrument successfully completes the span calibration, it will emit three short beeps and display the maximum span calibration value for two seconds.



**Note:** The max span calibration adjustment value shown is an indication of the relative health of the sensor. As a sensor loses sensitivity, the maximum adjustment level will approach the calibration gas concentration, letting you know when the sensor is losing sensitivity. Once the maximum span adjustment is within 10% of the calibration gas concentration, it is time to order a new sensor.

4. The instrument will then turn off.

**Note:** Once the calibration cycle is complete, the Toxi Vision IR CO<sub>2</sub> automatically returns to normal operation and the gas alarms may be activated. Disconnect the calibration assembly immediately after calibration.

**⚠WARNING** Use of non-standard calibration gas and/or calibration kit components when calibrating the Toxi Vision IR CO<sub>2</sub> can lead to inaccurate and potentially dangerous readings, and may void the standard Sperian Instrumentation warranty.

### 3.4 Failure to calibrate

Since two calibration cylinders are required to perform the calibration on the ToxiVision IR, this section will be divided into a section on zero calibration failure and a section on span calibration failure.

#### 3.4.1 Zero calibration failure

In the event of calibration failure, the “no” and “CAL” screens will be alternately displayed as shown below before the instrument returns to the gas reading screen.

Zero calibration failures in the Toxi Vision IR CO<sub>2</sub> often result from the attempt to calibrate the instrument in an atmosphere containing CO<sub>2</sub>. When an attempt to zero calibrate fails, the ToxiVision IR CO<sub>2</sub> will show “no CAL” in a series of screens.



In the case of a zero calibration failure, the “no” and “CAL” screens will be shown with the calibration bottle icon highlighted.

Zero calibration failures in the ToxiVision IR CO<sub>2</sub> can be caused by the following:

1. Attempts to calibrate the ToxiVision IR CO<sub>2</sub> in fresh air.
2. Using calibration gas that contains CO<sub>2</sub> for the zero calibration.
3. Sensor failure.

Following a failed zero calibration attempt, the triangular warning icon will appear in the current gas reading screen and the LED will blink until a successful calibration is made.

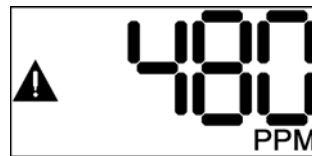

#### 3.4.2 Span calibration failure

In the case of a span calibration failure, the “no” and “GAS” screens will be shown with the warning symbol.



Span calibration failures can be caused by the following:

1. Expired calibration gas.
2. Calibration gas whose concentration fails to match the type or concentration expected by the instrument.
3. Sensor failure.

Following a failed span calibration attempt, the triangular warning icon will appear in the current gas reading screen and the LED and span bottle icon will blink until a successful calibration is made.

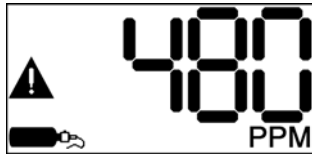

### 3.5 Forced zero calibration

If a zero calibration fails while using a cylinder of 0 PPM CO<sub>2</sub>, the Toxi Vision IR CO<sub>2</sub> can be forced to zero calibrate as follows.

1. Connect the cylinder of calibration gas containing 0 PPM CO<sub>2</sub> to the ToxiVision IR CO<sub>2</sub> as shown above in figure 3.2 and flow gas to the instrument for about 30 seconds until the reading stabilizes.
2. Once the reading has stabilized, press the MODE button three times within two seconds to begin the zero calibration sequence. The Toxi Vision IR CO<sub>2</sub> will briefly display "CAL" and then begin a 5 second countdown.
3. As soon as the alternating right and left 0's are shown on the screen, press and hold the MODE button.

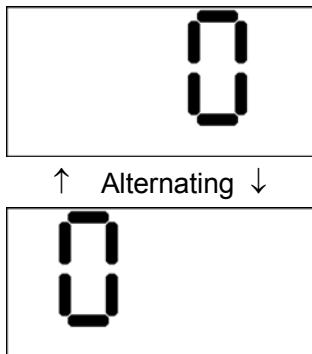

4. The forced zero calibration is complete when the instrument emits three short beeps and then moves on the span calibration procedure.

## 4. Maintenance

### 4.1 Replacing alkaline batteries

**⚠WARNING** Removal or replacement of alkaline batteries in potentially combustible atmospheres may lead to serious injury or death. The alkaline batteries used in the Toxi Vision IR CO<sub>2</sub> may only be removed or replaced in an atmosphere that is known to be free of combustible gas.

**⚠WARNING** To reduce the risk of explosion, do not mix old or used batteries with new batteries and do not

mix batteries from different manufacturers.

To replace the batteries:

1. Remove the six screws on the back of the Toxi Vision IR CO<sub>2</sub>.
2. Remove the back cover plate. The two AA alkaline batteries are located near the center of the main board.
3. Remove the old alkaline batteries and install new batteries. Be sure to align the polarity of the batteries in accordance with the diagram on the battery compartment.
4. Replace the back cover plate.
5. Reinstall the six screws on the back of the instrument that were removed in step 1.

**Note:** If the calibration due reminder is enabled, the ToxiVision IR must be calibrated following a battery change.

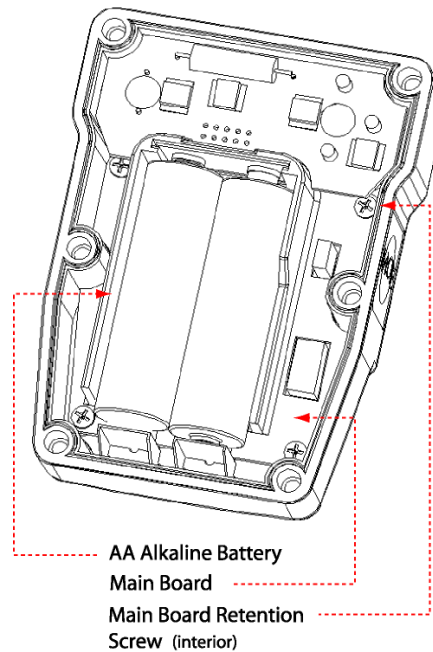

Figure 4.1: Interior view

**⚠WARNING** Use only Duracell MN1500 or Ultra MX1500, Eveready Energizer E91-LR6, or Eveready Energizer EN91 size AA 1.5V alkaline batteries. Substitution of batteries may impair intrinsic safety.

### 4.2 Charging NiMH batteries

The Nickel Metal Hydride (NiMH) batteries contained in the Toxi Vision IR CO<sub>2</sub> are encapsulated in the instrument for safety and may not be accessed by the user.

To charge the batteries, simply plug the Toxi Vision IR CO<sub>2</sub> into a standard

electrical socket using the charger that was delivered with the instrument. The Toxi Vision IR CO<sub>2</sub> should charge fully in 12 hours.

The NiMH battery in the ToxiVision may not be charged at temperatures lower than 5 degrees Celsius (40 degrees Fahrenheit) or higher than 38 degrees Celsius (100 degrees Fahrenheit). In the event that charging is attempted outside of the charging range, the instrument will display “too hot” or “too cold” as appropriate.

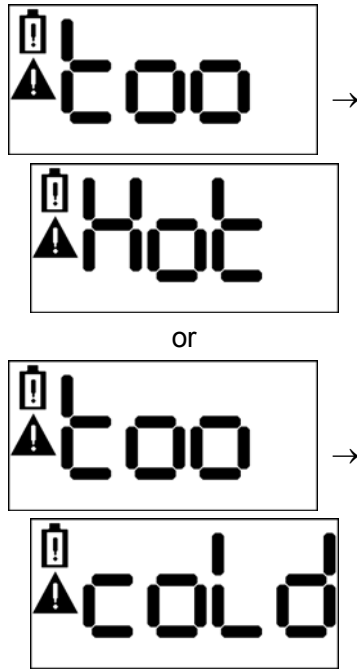

### 4.3 Replacing sensors

The sensor in the Toxi Vision IR CO<sub>2</sub> may require periodic replacement. To replace the sensor:

1. Loosen the six screws on the back of the Toxi Vision IR CO<sub>2</sub>.
2. Remove the back cover.
3. Remove the batteries.

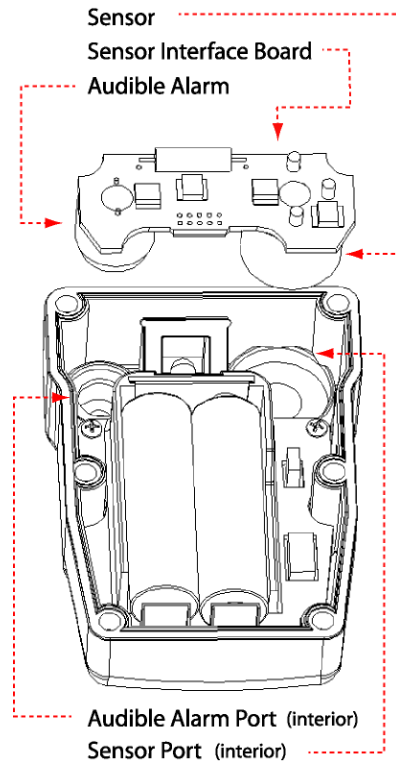

**Figure 4.3 Interior view with sensor interface board removed**

4. The sensor interface board is located in the top section of the instrument and can be removed by gently pulling it up from the main board.
5. Once the sensor interface board has been removed, gently remove the old sensor and install a new sensor of the same type.
6. Replace the sensor interface board. Be careful to properly align the connector pins, sensor and alarm gaskets before pressing the sensor interface board back into place.
7. Replace the batteries.
8. Replace the back cover.
9. Retighten the six screws on the back of the instrument that were removed in step 1.

**Note: The Toxi Vision IR CO<sub>2</sub> must be calibrated after any sensor change. See section 3.3 and 3.4 above for details on the zero and span calibration sequences.**

### 5. Direct programming

In the event that an instrument setting needs to be changed in the field and a PC with the appropriate software is not available, the Toxi Vision IR CO<sub>2</sub> can be

programmed directly with the MODE button.

**⚠WARNING** Reprogramming the Toxi Vision IR CO<sub>2</sub> is reserved for authorized personnel. Inappropriate changes made in the Advanced Menu may lead to inaccurate and potentially dangerous readings.

Turn the Toxi Vision IR CO<sub>2</sub> off. Then turn the Toxi Vision IR CO<sub>2</sub> back on, but instead of releasing the MODE button, continue to hold it. The “PC” screen will be shown in approximately 6 seconds.



Continue to hold the MODE button for about 15 additional seconds until the “set” screen is shown, then release the MODE button.



Click the MODE button once with “ini” shown. After a few seconds, the “ini” screen will be replaced by the “on MAX” or “OFF MAX” screen.



Or



### 5.1 MAX on or off

With MAX set to on, the maximum reading that the instrument has registered in this operating session can be accessed from the current gas readings screen by pressing the MODE button twice (once to turn on the backlight and once to show the MAX screen).

With the MAX setting off, the instrument will not show the max readings during normal operation.

Click the MODE button to change the setting. Once 15 seconds elapse without a

change to the setting, the instrument will move on to the STEL setting.

### 5.2 STEL on or off

The STEL (Short Term Exposure Limit) for a particular toxic gas is the maximum average concentration to which an unprotected worker may be exposed in any 15 minute interval during the day. The STEL value displayed by the Toxi Vision IR CO<sub>2</sub> is the average concentration for the most recently completed 15 minutes of operation.

**Note:** For the first 15 minutes after the Toxi Vision IR CO<sub>2</sub> is initially turned on the STEL reading is a projected value. The Toxi Vision IR CO<sub>2</sub> will begin projecting a STEL value after the first 30 seconds of operation. For the first 30 seconds the STEL screen will show an “X” where the reading should be.

The STEL reading is continuously updated. Audible and visible alarms will be activated immediately any time the most recent 15-minute average exceeds the STEL alarm set point.

When the Toxi Vision IR CO<sub>2</sub> moves to the STEL reading, it will show “StL” and then the on of off setting.



or



Click the MODE button to change the setting. Once 15 seconds elapse without a change to the setting, the instrument will move on to the TWA reading.

### 5.3 TWA on or off

Time Weighted Average or TWA values are calculated by taking the sum of exposure to a particular toxic gas in the current operating session in terms of parts-per-million-hours and dividing by an eight-hour period.

**Note:** It is not possible to calculate a toxic gas TWA reading until the Toxi Vision IR CO<sub>2</sub> has been operating for 15 minutes. For the first 15 minutes after start-up, the TWA screen will show an “X” in place of the calculation. After 15 minutes, the TWA calculation will be shown.

When the Toxi Vision IR CO<sub>2</sub> moves to the TWA reading, it will show “tWA” and then the on or off setting.



or



Click the MODE button to change the setting. Once 15 seconds elapse without a change to the setting, the instrument will turn itself off.

## Exploded View

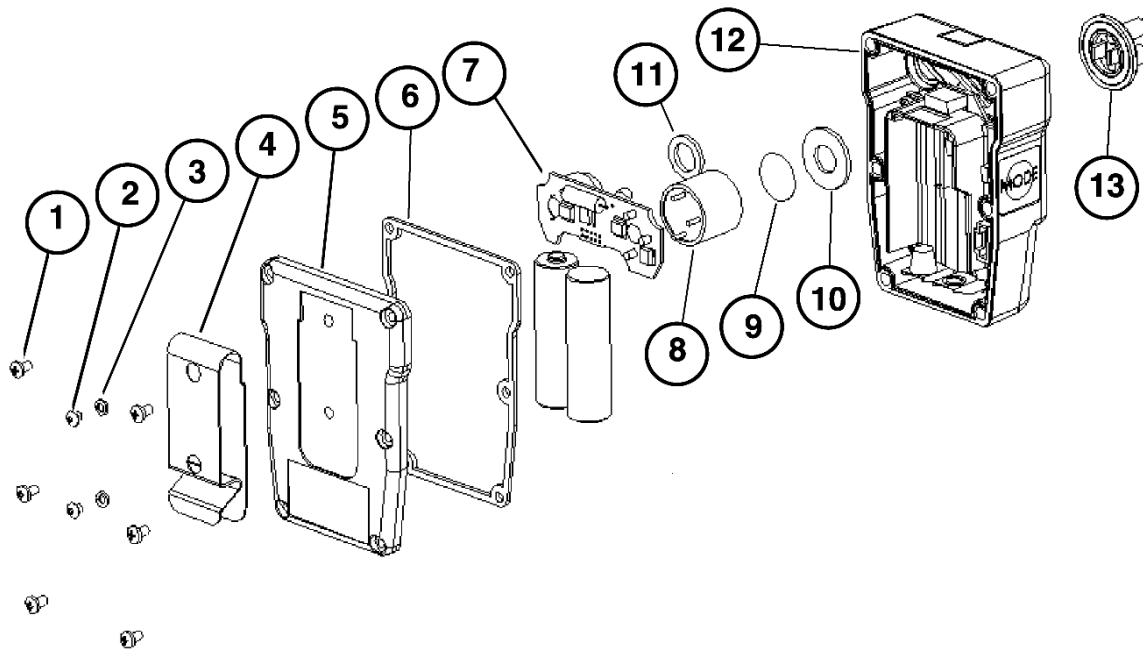

- |     |            |   |
|-----|------------|---|
| 1.  | 05-1147(6) | Case retention screws   |
| 2.  | 05-630(2)  | Belt clip retention screws  |
| 3.  | 05-213(2)  | Belt clip retention washers   |
| 4.  | 55-392(1)  | Belt clip   |
| 5.  | 10-391(1)  | Bottom housing  |
| 6.  | 34-063(1)  | Main gasket   |
| 7.  | **         | Sensor interface board  |
| 8.  | **         | Sensor  |
| 9.  | **         | Sensor filter   |
| 10. | 34-065(1)  | Sensor gasket   |
| 11. | 34-066(1)  | Alarm gasket  |
| 12. | 10-390(1)  | Top housing   |
| 13. | 54-38-01   | Calibration/sample draw adapter   |
| **  |            | Sensor interface board, sensor and sensor filter vary with instrument type. |

## Appendix A: Calibration Frequency Recommendation

One of the most common questions that we are asked at Sperian Instrumentation is: **“How often should I calibrate my gas detector?”**

---

### Sensor Reliability and Accuracy

---

Today’s sensors are designed to provide years of reliable service. In fact, many sensors are designed so that with normal use they will only lose 5% of their sensitivity per year or 10% over a two-year period. Given this, it should be possible to use a sensor for up to two full years without any significant loss of sensitivity.

---

### Verification of Accuracy

---

With so many reasons why a sensor can lose sensitivity and given the fact that dependable sensors can be key to survival in a hazardous environment, frequent verification of sensor performance is paramount.

There is only one sure way to verify that a sensor can respond to the gas for which it is designed. That is to expose it to a known concentration of target gas and compare the reading with the concentration of the gas. This is referred to as a “bump” test. This test is very simple and takes only a few seconds to accomplish. **The safest course of action is to do a “bump” test prior to each day’s use.** It is not necessary to make a calibration adjustment if the readings fall between 90%\* and 120% of the expected value. As an example, if a CO sensor is checked using a gas concentration of 50 PPM it is not necessary to perform a calibration unless the readings are either below 45 PPM or above 60 PPM.

---

### Lengthening the Intervals between Verification of Accuracy

---

We are often asked whether there are any circumstances in which the period between accuracy checks may be lengthened.

Sperian Instrumentation is not the only manufacturer to be asked this question! One of the professional organizations to which Sperian

Instrumentation belongs is the Industrial Safety Equipment Association (ISEA). The “Instrument Products” group of this organization has been very active in developing a protocol to clarify the minimum conditions under which the interval between accuracy checks may be lengthened.

A number of leading gas detection equipment manufacturers have participated in the development of the ISEA guidelines concerning calibration frequency. Sperian Instrumentation procedures closely follow these guidelines.

If your operating procedures do not permit daily checking of the sensors, Sperian Instrumentation recommends the following procedure to establish a safe and prudent accuracy check schedule for your Sperian Instrumentation instruments:

1. During a period of initial use of at least 10 days in the intended atmosphere, check the sensor response daily to be sure there is nothing in the atmosphere that is poisoning the sensor(s). The period of initial use must be of sufficient duration to ensure that the sensors are exposed to all conditions that might have an adverse effect on the sensors.
2. If these tests demonstrate that it is not necessary to make adjustments, the time between checks may be lengthened. The interval between accuracy checking should not exceed 30 days.
3. When the interval has been extended the toxic and combustible gas sensors should be replaced immediately upon warranty expiration. This will minimize the risk of failure during the interval between sensor checks.
4. The history of the instrument response between verifications should be kept. Any conditions, incidents, experiences, or exposure to contaminants that might have an adverse effect on the calibration state of the sensors should trigger immediate re-verification of accuracy before further use.

5. Any changes in the environment in which the instrument is being used, or changes in the work that is being performed, should trigger a resumption of daily checking.
6. If there is any doubt at any time as to the accuracy of the sensors, verify the accuracy of the sensors by exposing them to known concentration test gas before further use.

Gas detectors used for the detection of oxygen deficiencies, flammable gases and vapors, or toxic contaminants must be maintained and operated properly to do the job they were designed to do. Always follow the guidelines provided by the manufacturer for any gas detection equipment you use!

If there is any doubt regarding your gas detector’s accuracy, do an accuracy check! All it takes is a few moments to verify whether or not your instruments are safe to use.

---

### One Button Auto Calibration

---

While it is only necessary to do a “bump” test to ensure that the sensors are working properly, all current Sperian Instrumentation gas detectors offer a one button auto calibration feature. This feature allows you to calibrate a Sperian Instrumentation gas detector in about the same time as it takes to complete a “bump” test. The use of automatic bump test and calibration stations can further simplify the tasks, while automatically maintaining records.

**Don’t take a chance  
with your life.  
Verify accuracy frequently!**

Please read also Sperian Instrumentation’s applications note: AN20010808 “Use of ‘equivalent’ calibration gas mixtures”. This application note provides procedures to ensure safe calibration of LEL sensors that are subject to silicone poisoning.

The Sperian Protection Instrumentation, LLC website is located at <http://www.biosystems.com>

# Toxi Vision IR CO<sub>2</sub>

Software Version \_\_\_\_\_

Vibrating Motor

Datalogging

Serial Number \_\_\_\_\_

MFG Date \_\_\_\_\_

## Sperian Instrumentation Toxi Vision IR CO<sub>2</sub> Standard Warranty

### General

Sperian Protection Instrumentation, LLC (hereafter Sperian) warrants gas detectors, sensors and accessories manufactured and sold by Sperian, to be free from defects in materials and workmanship for the periods listed in the tables below.

Damages to any Sperian products that result from abuse, alteration, power fluctuations including surges and lightning strikes, incorrect voltage settings, incorrect batteries, or repair procedures not made in accordance with the Instrument's Reference Manual are not covered by the Sperian standard warranty.

The obligation of Sperian under this warranty is limited to the repair or replacement of components deemed by the Sperian Instrument Service Department to have been defective under the scope of this standard warranty. To receive consideration for warranty repair or replacement procedures, products must be returned with transportation and shipping charges prepaid to Sperian at its manufacturing location in Middletown, Connecticut, or to a Sperian Authorized Warranty Service Center. It is necessary to obtain a return authorization number from Sperian prior to shipment.

THIS WARRANTY IS EXPRESSLY IN LIEU OF ANY AND ALL OTHER WARRANTIES AND REPRESENTATIONS, EXPRESS OR IMPLIED, INCLUDING BUT NOT LIMITED TO, THE WARRANTY OF FITNESS FOR A PARTICULAR PURPOSE. SPERIAN WILL NOT BE LIABLE FOR LOSS OR DAMAGE OF ANY KIND CONNECTED TO THE USE OF ITS PRODUCTS OR FAILURE OF ITS PRODUCTS TO FUNCTION OR OPERATE PROPERLY.

### Instrument & Accessory Warranty Periods

Product(s)	Warranty Period
ToxiVision IR CO <sub>2</sub>	As long as the instrument is in service
Battery packs and chargers, sampling pumps and other components, which by their design are consumed or depleted during normal operation, or which may require periodic replacement	One year from the date of purchase

### Sensor Warranty Periods

Instrument(s)	Sensor Type	Warranty Period
ToxiVision IR CO <sub>2</sub>	IR	1 Year