

Biosystems is now



Toxi Vision IR CH₄

**Single Gas
Detector**

**Reference
Manual**



**Sperian Instrumentation
651 South Main Street
Middletown, CT 06457
(800) 711-6776
(860) 344-1079
Fax (860) 344-1068
Part number 13-316
Version 1.10
14FEB2008**

WARNING

THE TOXI VISION IR CH₄ PERSONAL PORTABLE GAS DETECTORS HAVE BEEN DESIGNED FOR THE DETECTION AND MEASUREMENT OF POTENTIALLY HAZARDOUS ATMOSPHERIC CONDITIONS.

IN ORDER TO ASSURE THAT THE USER IS PROPERLY WARNED OF POTENTIALLY DANGEROUS ATMOSPHERIC CONDITIONS, IT IS ESSENTIAL THAT THE INSTRUCTIONS IN THIS REFERENCE MANUAL BE READ, FULLY UNDERSTOOD, AND FOLLOWED.

**Toxi Vision IR CH₄ Reference Manual
Sperian Part Number 13-316
Version 1.10
Copyright 2008**

**Sperian Protection Instrumentation, LLC
Middletown, Connecticut 06457**

All rights reserved.

No page or part of this operation manual may be reproduced in any form without written permission of the copyright owner shown above.

Sperian reserves the right to correct typographical errors.

Table of Contents

Certifications	4
ATEX Label Requirement	4
Warnings and Cautions	4
A. Signal Words.....	4
B. Warnings.....	5
1. Overview	6
1.1 Methods of sampling.....	6
1.2 IR CH ₄ Sensor.....	6
1.3 LEL definition	6
1.4 Alarm logic	6
1.4.1 Gas alarms	6
1.4.2 Battery alarms.....	7
1.4.3 Missing sensor alarm.....	7
1.4.4 Optional vibrating alarm.....	7
1.5 Calibration	7
1.6 Communications	7
1.7 Features	7
1.7.1 Security beep.....	7
1.7.2 Latching danger alarm.....	7
1.7.3 Calibration due warnings.....	8
1.8 Data storage.....	8
1.8.1 Black box datalogger	8
1.8.2 Event logger.....	8
1.9 Design components	8
1.10 Standard accessories	9
1.11 Toxi Vision IR Kits.....	9
1.11.1 Value pack CH ₄ kits	9
1.11.2 Complete kits.....	9
2. Instrument Functions	9
2.1 Turning the Toxi Vision IR CH ₄ on	9
2.2 Backlight.....	10
2.3 MAX readings	10
2.4 Turning the Toxi Vision IR off	10
2.5 Sampling	11
2.5.1 Sample draw kit usage	11
2.6 Error Messages.....	11
3. Calibration	11
3.1 Verification of accuracy.....	11
3.2 Response (bump) testing.....	12
3.3 Fresh air/zero calibration	12
3.4 Span Calibration	13
3.5 Failure to calibrate	13
3.5.1 Forced fresh air/zero calibration.....	14
3.6 Fresh air calibration in a contaminated atmosphere	14

4. Maintenance	14
4.1 Replacing alkaline batteries	14
4.2 Charging NiMH batteries	15
4.3 Replacing sensors	15
5. Direct programming	16
5.1 MAX on or off	16
5.2 LEL or CH ₄	16
Exploded View Exploded View	17
Appendix A: Calibration Frequency Recommendation	18
Sperian Instrumentation Toxi Vision IR CH₄ Standard Warranty	19

Certifications

UL Class I, Division 1, Groups A, B, C, D

NEPSI (China) Ex d ia IIC T4

ATEX: 07 ATEX 0616084

Ex d ia IIC T4

IECEX: IECEX UL 07.0006

ATEX Label Requirement

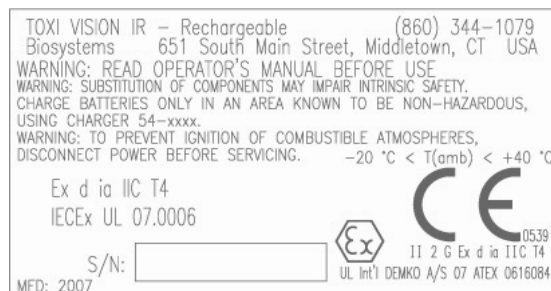
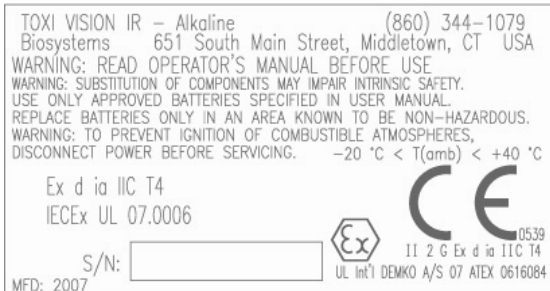

Warnings and Cautions

A. Signal Words

The following signal words, as defined by ANSI Z535.4-1998, are used in the Toxi Vision IR CH₄ Operator's Guide.

⚠ DANGER indicates an imminently hazardous situation which, if not avoided, will result in death or serious injury.

⚠ WARNING indicates a potentially hazardous situation which, if not avoided, could result in death or serious injury.

⚠ CAUTION indicates a potentially hazardous situation, which if not avoided, may result in moderate or minor injury.

CAUTION used without the safety alert symbol indicates a potentially hazardous situation which, if not avoided, may result in property damage.

B. Warnings

1. **⚠️WARNING** The Toxi Vision IR CH₄ personal, portable gas detector has been designed for the detection of accumulations of methane. An alarm condition indicates the presence of a potentially life-threatening hazard and should be taken very seriously.
2. **⚠️WARNING** In the event of an alarm condition it is important to follow established procedures. The safest course of action is to immediately leave the affected area, and to return only after further testing determines that the area is once again safe for entry. Failure to immediately leave the area may result in serious injury or death.
3. **⚠️WARNING** Use only Duracell MN1500 or Ultra MX1500, Eveready Energizer E91-LR6, or Eveready Energizer EN91 size AA 1.5V alkaline batteries. Substitution of batteries may impair intrinsic safety.
4. **⚠️WARNING** To reduce the risk of explosion, do not mix old or used batteries with new batteries and do not mix batteries from different manufacturers.
5. **⚠️WARNING** The accuracy of Toxi Vision IR CH₄ instruments should be checked periodically with known concentration calibration gas. Failure to check accuracy can lead to inaccurate and potentially dangerous readings.
6. **⚠️WARNING** A sensor that cannot be calibrated or is found to be out of tolerance must be replaced immediately. An instrument that fails calibration may not be used until testing with known concentration test gas determines that accuracy has been restored, and the instrument is once again fit for use.
7. **⚠️WARNING** Do not reset the calibration gas concentration setpoints in the Toxi Vision IR CH₄ unless the concentrations of your calibration gas differ from the concentrations of the calibration gas that is normally supplied by Sperian for use in calibrating the Toxi Vision IR CH₄.
8. **⚠️WARNING** Use of non-standard calibration gas and/or calibration kit components when calibrating the Toxi Vision IR CH₄ can lead to dangerously inaccurate readings and may void the standard Sperian Instrumentation warranty. Sperian Instrumentation offers calibration kits and long-lasting cylinders of test gas specifically developed for easy calibration. Customers are strongly urged to use only Sperian calibration materials when calibrating the Toxi Vision IR CH₄.
9. **⚠️WARNING** Substitution of components may impair intrinsic safety.
10. **⚠️WARNING** For safety reasons the Toxi Vision IR CH₄ must be operated by qualified personnel only. Read, understand and follow the directions set forth in this reference manual before operating the Toxi Vision IR CH₄.
11. **⚠️WARNING** The Toxi Vision IR CH₄ has been tested for intrinsic safety in Explosive Gas/AIR (21.0% O₂) Only.

1. Overview

The Toxi Vision IR CH₄ is a single sensor gas detector designed to detect methane (CH₄).

Methane (CH₄) is a combustible gas that is normally a vapor at room temperature.

The Toxi Vision IR CH₄ includes numerous features designed to meet specific user requirements. This chapter will broadly discuss the use and capabilities of the Toxi Vision IR CH₄.

1.1 Methods of sampling

The Toxi Vision IR CH₄ may be used in either diffusion or sample-draw mode. In either mode, the gas sample must enter the sensor compartment for the instrument to register a gas reading.

In diffusion mode, the atmosphere reaches the sensor by diffusing through the sensor port on the front of the instrument. Normal air movements are enough to carry the sample to the sensor. The sensor reacts quickly to changes in the concentration of the gas being measured.

It is also possible to use the Toxi Vision IR CH₄ to sample remote locations with the hand-aspirated sample-draw kit that is available separately. During remote sampling, the gas sample is drawn into the sensor compartment through the probe assembly and a length of tubing.

1.2 IR CH₄ Sensor

The ToxiVision IR uses an infrared sensor to ascertain the amount of the target gas in the atmosphere. Inside the sensor infrared light is passed through the gas sample into a prism that allows the light's intensity at specific wavelengths to be measured. The intensity of the light in the prism at a certain wavelength varies with the amount of CH₄ present in the atmosphere. The detector reads the intensity of the light in the prism at the known wavelength and converts it into a gas reading.

The principle advantage of using an infrared sensor over a traditional hot-bead LEL sensor is that the IR sensor is more resilient and not susceptible to poisoning.

The sensor used in the ToxiVision IR CH₄ has been designed to provide a linear response to methane, but it will also respond to other hydrocarbons. In some cases, the sensor will respond with a level that is higher than the actual gas level. In other cases it will respond with a level that is lower than the actual gas level.

Unlike other types of sensors used to measure combustible gases and vapors, the sensor used in the ToxiVision IR CH₄ does not respond to hydrogen.

⚠WARNING The sensor in the ToxiVision IR CH₄ does not respond to hydrogen. The ToxiVision IR CH₄ may not be used to detect hydrogen (H₂).

1.3 LEL definition

As an environment becomes contaminated with combustible gases and/or vapors, concentrations can climb until they eventually reach ignitable or explosive levels. The minimum amount of a combustible gas or vapor in air that will explosively burn if a source of ignition is present is known as the Lower Explosive Limit (LEL). Toxi Vision IR CH₄ combustible gas readings are given in percent LEL, with a range of zero to two hundred percent. The Toxi Vision IR CH₄ combustible gas sensor is specifically designed to respond to methane (CH₄), but will also respond to other hydrocarbons.

The Lower Explosive Limit for CH₄ is 5.0% by volume.

5.0% CH₄ by Volume = 100% LEL

⚠DANGER A reading of over 100% LEL (or over 5.0%/vol CH₄) indicates an explosive atmosphere. Failure to leave the area immediately may result in serious injury or death!

1.4 Alarm logic

1.4.1 Gas alarms

The ToxiVision IR CH₄ includes a three-tiered gas alarm to let the user know of increasing levels of danger. The standard warning/low and danger/high gas alarms are user-adjustable and may be set anywhere at or below 20% LEL. In the event of a gas reading that exceeds 100% LEL or 5.0%/volume CH₄, the instrument will enter the over LEL alarm.

Alarm	Default LEL Alarm level
Low	10% LEL
High	20% LEL
Over LEL	100% LEL

Default Alarm Levels for Toxi Vision IR CH₄

When an alarm set point is exceeded the loud two-tone audible alarm sounds, and the bright red LED alarm light flashes. The instrument reading will continue to be shown on the display.

In the event that the instrument detects combustible gas and the gas reading exceeds 100% LEL, the Toxi Vision IR CH₄ will show a specialized warning to indicate that the atmosphere has reached the combustible threshold.

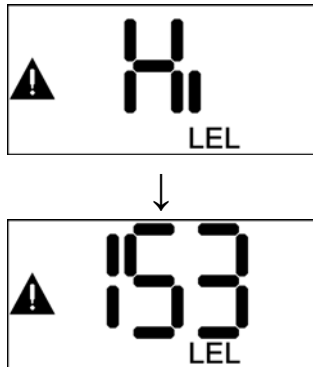

⚠ DANGER A reading of over 100% LEL (or over 5.0%/vol CH₄) indicates an explosive atmosphere. Failure to leave the area immediately may result in serious injury or death!

1.4.2 Battery alarms

The Toxi Vision IR CH₄ is equipped with a three stage low battery alarm.

When battery voltage is reduced to the point where there is approximately one hour of battery life remaining, the battery icon will be displayed on the LCD.



When battery voltage is reduced to the point where this is approximately 15 minutes of battery life remaining, the battery and warning icons will be displayed on the LCD.



If the battery voltage is reduced to the point where the battery can no longer power the instrument, the instrument will go into a danger alarm while displaying "OFF" on the screen as long as it can or until the MODE button is pressed to turn the instrument off.



1.4.3 Missing sensor alarm

If the Toxi Vision IR CH₄ determines that the sensor is missing, the instrument will go into alarm and indicate F1 on the screen with the warning symbol.

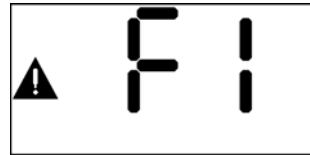

See section 2.6 for a full list of error messages.

1.4.4 Optional vibrating alarm

A vibrating alarm is available as an option for instruments that will be used in high noise areas.

1.5 Calibration

The Toxi Vision IR CH₄ features one-button fresh air/zero and span calibration functions.

Calibration procedures are discussed in detail in chapter 3.

1.6 PC Communications

The Toxi Vision IR CH₄ features a built-in IrDA port for communication between a PC and the instrument. The IrDA port is located under the alarm LED. See figure 1.9 below.

1.7 Features

1.7.1 Security beep

The Toxi Vision IR CH₄ includes a security beep that can be enabled or disabled according to the needs of the user. At the default interval, the Toxi Vision IR CH₄ will emit a short beep every 60 seconds to remind the user that the instrument is active.

1.7.2 Latching danger alarm

The Toxi Vision IR CH₄ includes a latching danger alarm that can be enabled or disabled according to the needs of the user.

With the latching alarm enabled, once the Toxi Vision IR CH₄ enters a danger alarm, it will remain in alarm even after the readings have dropped back below the danger alarm threshold. To acknowledge the alarm and return to normal operation, press the MODE button.

With the latching alarm disabled, user intervention is not required following a danger alarm. The Toxi Vision IR CH₄ will automatically return to normal operation and the alarms will cease as soon as the reading drops below the danger alarm threshold.

1.7.3 Calibration due warnings

The Toxi Vision IR CH₄ includes optional calibration due warnings. The calibration due warning option is disabled at the factory, but can be enabled with BioTrak software for any period between 1 and 180 days. Upon instrument startup, if the calibration due warning is enabled and the instrument is due for calibration, the Toxi Vision IR will show “cal due” in the startup screens. If the instrument is due for fresh air/zero calibration, the triangular warning symbol will be shown with the “cal due” message and will then be shown on the current gas readings screen. If the instrument is due for span calibration, the triangular warning symbol and the calibration bottle icon will be shown with the “cal due” message and both symbols will then be shown on the current gas readings screen.



1.8 Data storage

Alkaline versions of the Toxi Vision IR CH₄ come equipped with an Event Logger as standard equipment.

Rechargeable versions of the Toxi Vision IR CH₄ come equipped with the Event Logger and a Black Box Datalogger as standard equipment. The rechargeable version of the Toxi Vision IR CO₂ may also be purchased with a fully enabled datalogger.

The upgrades necessary to convert the Black Box Datalogger into a fully enabled Datalogger must be performed at the factory. Call Sperian Instrumentation for details.

Note: Sperian Instrumentation’s BioTrak software is used to extract and view data from the Toxi Vision IR CH₄.

1.8.1 Black box datalogger

A black box data datalogger is a standard feature in the rechargeable version of the Toxi Vision IR CH₄. The “black box” is continually in operation whether the user is aware of it or not. The black box stores important information such as gas readings, turn-on times, turn-off times, temperatures, battery conditions, the most recent calibration date and settings, types of sensor currently installed, sensor serial number, warranty expiration and service due dates, and current alarm settings.

There is a finite amount of memory storage available in the black box data recorder. Once the memory is “full”, the Toxi Vision IR CH₄ will begin to write the new data over the oldest data. The black box data recorder will store approximately 40 hours of data in one-minute increments before it begins to write new data over the oldest data. In this way, the newest data is always conserved.

To extract the information from the black box data recorder, the Toxi Vision IR CH₄ must be returned to Sperian Instrumentation. Once the data is downloaded from the instrument, a report will be generated. The unit and the report will then be returned to the user. Simply call Sperian’s Instrument Service Department to obtain a return authorization number. There is no charge for the downloading service, but the user is responsible for any freight charges incurred.

1.8.2 Event logger

An event logger is a standard feature on all versions of the Toxi Vision IR CH₄. The event logger stores data associated with alarm conditions. Each (alarm) event includes the following data for each of the installed sensors: Sensor type, max reading, average reading, start time, end time and duration of the event. The Toxi Vision IR CO₂ stores the 20 most recent events. Once 20 events have been stored, the Toxi Vision IR CO₂ will begin to systematically overwrite the data from the oldest event in memory with data from new events. One event may be a combination of different alarms occurring simultaneously or in immediate succession. The event logger may be downloaded using s’ BioTrak software. The PC must be equipped with IrDA to provide a connection.

1.9 Design components

- 1. Case:** The instrument is enclosed in a solid, metal-plated ABS case. A black EPDM gasket between the upper and lower sections of the case protects against leakage or exposure to liquids.
- 2. Front face:** The front face of the instrument houses the graphics capable LCD display, sensor port, LED alarm and audible alarm port.
- 3. LCD display:** The liquid crystal display (LCD) allows display of gas readings, messages and other information. A built-in backlight allows the display to be read even in low light conditions.

4. **Alarm light (LED)** A bright red LED (light-emitting diode) alarm light provides a visual indication of the alarm state. The light is visible from the front and top of the instrument.
5. **IrDA Port:** The IrDA port is located under the LED alarm light and is used to communicate with a PC.

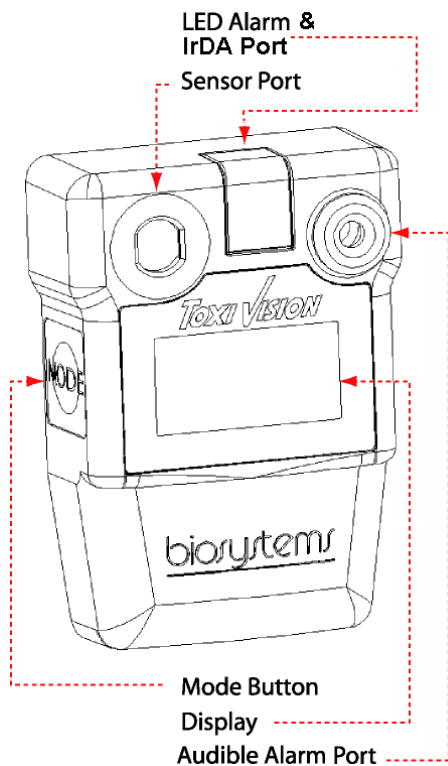

Figure 1.9 Exterior front view.

6. **MODE button:** The large push-button on the left side of the instrument is called the MODE button. The MODE button is used to turn the Toxi Vision IR CH₄ on and off, to turn on the backlight, to view the MAX screen and to access the automatic calibration sequences.
7. **Audible alarm orifice:** A cylindrical resonating chamber contains the loud audible alarm.
8. **Sensor port:** The combustible gas sensor is located just below the sensor port at the upper left corner of the instrument.
9. **Bottom surface:** The belt clip attaches to the bottom surface of the instrument.

1.10 Standard accessories

Standard accessories with every Toxi Vision IR CH₄ include installed sensor, reference manual, quick reference card and calibration/sample draw adapter.

Alkaline versions include a set of 2 AA alkaline batteries.

Rechargeable versions include a built-in rechargeable NiMH battery and a charger.

Optional accessories include manual (hand-aspirated) sample draw kit, PC software kit (NiMH instrument only), rubber boot and vibrating alarm.

Toxi Vision IR CH₄ instruments that are not ordered in a complete kit or a value pack are delivered in a cardboard box.

1.11 Toxi Vision IR CH₄ Kits

The Toxi Vision IR CH₄ can be purchased as part of a value pack or complete kit that includes everything needed to calibrate the instrument and operate the instrument in diffusion mode.

1.11.1 Value pack CH₄ kits

Toxi Vision IR CH₄ value packs include all standard accessories, calibration fittings, 34-liter cylinder of calibration gas, and fixed flow rate regulator in a foam-lined, hard-shell carrying case.

1.11.2 Complete kits

Toxi Vision IR CH₄ complete kits include all standard accessories, calibration fittings, 103-liter cylinder of calibration gas, and fixed flow rate regulator in a foam-lined, hard-shell carrying case.

2. Instrument Functions

Field operation of the Toxi Vision IR CH₄ is controlled entirely through the MODE button, which is located on the left side of the instrument.

The MODE button is used to turn the Toxi Vision IR CH₄ on and off, to turn on the backlight, to access MAX gas readings for the current session and to initiate the fresh air/zero and span calibration functions.

2.1 Turning the Toxi Vision IR CH₄ on

Press and hold the MODE button until the following display test screen is shown, then release the MODE button.

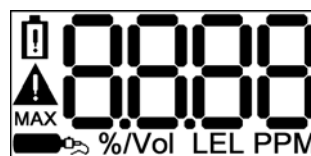

At start-up, the Toxi Vision IR CH₄ will automatically go through a basic electronic self-test and start-up sequence that will take

approximately sixty seconds. During the self-test sequence, the display backlight will momentarily turn on.

The Toxi Vision IR CH₄ will then display the software version, followed by the sensor type. If the instrument is equipped with a fully enabled datalogger, "dL" will be shown.

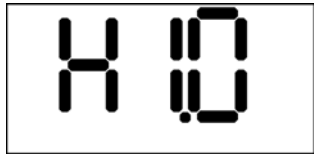

The warning alarm levels (indicated by Lo) will then be displayed, followed by the danger alarm levels (indicated by Hi). The instrument will also test the low and high audible alarms.



↑ Alternate 3 times ↓

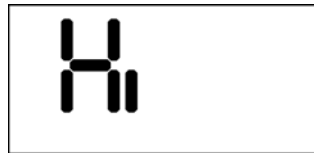

↑ Alternates 3 times ↓



In rechargeable versions, if the calibration due warning is enabled and the Toxi Vision IR CH₄ is due for calibration "cal" "due" will be shown. If the triangular warning symbol alone is shown, then the instrument is due for zero

calibration. If the triangular warning symbol and the bottle icon are shown then the instrument is due for span calibration.

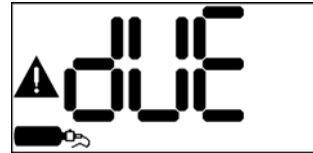

The instrument will then proceed with a thirty second warm up cycle.



At the end of the warm up cycle the current gas reading will be displayed.



2.2 Backlight

The Toxi Vision IR CH₄ includes a backlight that is automatically turned on during an alarm condition. The backlight can also be manually activated while the current gas reading is displayed by pressing the MODE button once. The backlight will automatically turn itself off in about twenty seconds.

2.3 View MAX readings

From the current gas reading screen, press the MODE button once to activate the backlight and then once more to view the MAX value screen. The MAX value represents the peak reading recorded by the instrument during the current operating session.



2.4 Turning the Toxi Vision IR off

To turn the Toxi Vision IR CH₄ off, press and hold the MODE button down until the instrument beeps three times and OFF is displayed.

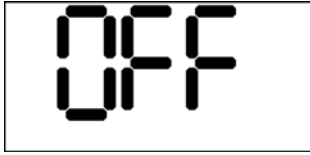

Once OFF is displayed, release the MODE button. The instrument has been successfully turned off when the display goes blank.

2.5 Sampling

The Toxi Vision IR CH₄ may be used in either diffusion or sample-draw mode. In either mode, the gas sample must enter the sensor compartment for the instrument to register a gas reading.

In diffusion mode, the atmosphere reaches the sensor by diffusing through the sensor port on the front of the instrument. Normal air movements are enough to carry the sample to the sensor. The sensor reacts quickly to changes in the concentration of the gas being measured.

It is also possible to use the Toxi Vision IR CH₄ to sample remote locations with the hand-aspirated sample-draw kit that is available separately. During remote sampling, the gas sample is drawn into the sensor compartment through the probe assembly and a length of tubing.

2.5.1 Sample draw kit usage

1. Connect the end of the hose that is closer to the squeeze bulb to the sample draw adapter. Then connect the other end of the hose to the sample probe.
2. Attach the sample draw adapter to the Toxi Vision IR CH₄.
3. Cover the end of the sample draw probe assembly with a finger, and squeeze the aspirator bulb. If there are no leaks in the sample draw kit components, the bulb should stay deflated for a few seconds.
4. Insert the end of the sample probe into the location to be sampled.
5. Squeeze the aspirator bulb several times to draw the sample from the remote location to the sensor compartment. Allow one squeeze of the bulb for every one foot of sampling hose for the sample to reach the sensors. Continue to squeeze the bulb for an additional 45 seconds or until readings stabilize.
6. Note the gas measurement readings.

CAUTION: Hand aspirated remote sampling only provides continuous gas readings for the area in which the probe is located when the bulb is being continuously squeezed.

Note: Each time a reading is desired, it is necessary to squeeze the bulb a sufficient number of times to bring a fresh sample to the sensor compartment.

2.6 Error Messages

The ToxiVision IR microprocessor monitors the instrument continuously. When a problem is found the instrument will show an error message.

Error #	Detail
F 1	No Sensor Installed
F 2	Bad Unit data read from flash / Unit will re-initialize
F 3	Bad Sensor data read from flash / Sensor data will re-initialize
F 4	Bad Flash memory erase / Unit turns off and will not turn back on again
F 5	Bad Flash memory write
F 6	No vibrator installed / Vibrator installed and not working

If an error message is shown, stop using the detector and contact Sperian Instrumentation or you local distributor for further information.

3. Calibration

The Toxi Vision IR CH₄ features fully automated fresh air/zero and span calibration functions. The MODE button is used to initiate the automatic calibration sequence. Calibration adjustments are made automatically by the instrument.

⚠WARNING The Toxi Vision IR CH₄ must be calibrated on the methane scale using methane (CH₄) calibration gas. The default calibration gas value for the Toxi Vision IR CH₄ is 50% LEL. The appropriate calibration gas level for the 50% LEL default calibration gas setting is 2.50%/vol. CH₄. Use of inappropriate calibration gas may lead to inaccurate and potentially dangerous readings.

3.1 Verification of accuracy

Calibration of the Toxi Vision IR CH₄ is a two step procedure.

Step one is to take the Toxi Vision IR CH₄ to an area where the atmosphere is known to be fresh and check the readings. If the readings differ from those expected in fresh air, then a

fresh air calibration adjustment must be made as discussed below in section 3.3.

Step two is to make sure the sensor is accurate by exposing it to a test gas of known concentration and noting the sensor response. The reading is considered to be accurate when the displayed value falls between 90%* and 120% of the expected value for the gas being used. If readings are considered accurate, there is no need to adjust your gas detector. If the readings are inaccurate, the instrument must be span calibrated before further use as discussed in section 3.4.

* **The Canadian Standards Association (CSA) requires the instrument to undergo calibration when the displayed value during a bump test fails to fall between 100% and 120% of the expected value for the gas.**

⚠WARNING Accuracy of the Toxi Vision IR CH₄ should be checked periodically with known concentration calibration gas. Failure to check accuracy can lead to inaccurate and potentially dangerous readings.

3.2 Response (bump) testing

The accuracy of the Toxi Vision IR CH₄ may be verified at any time by a simple functional (bump) test.

To perform a response (bump) test, do the following:

1. Turn the Toxi Vision IR CH₄ on and allow the instrument to complete the warm up period.
2. Make sure the instrument is located in fresh air.
3. Verify that the current gas readings match the concentrations present in fresh air. The reading should be shown as 0% LEL in fresh air. If any other level is shown, perform the fresh air / zero calibration as discussed below in section 3.3 before proceeding to step 4.
4. Apply the calibration gas as shown below in figure 3.2.
5. Wait for the readings to stabilize. (Forty-five seconds to one minute is usually sufficient.)
6. Note the readings. Readings are considered sufficiently accurate if they are between 90%* and 120% of the expected reading. If the readings are considered accurate, then the instrument may be used without further adjustment.

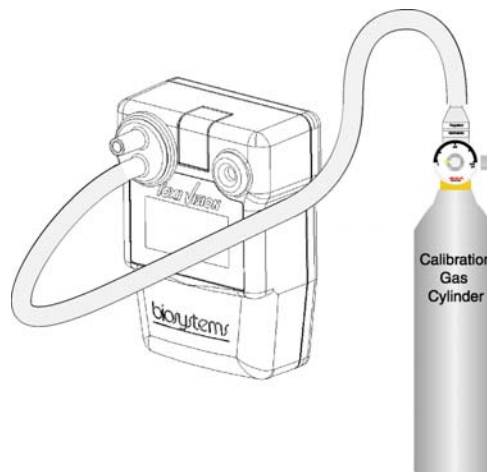

Figure 3.2: Proper bump-test/span calibration set-up

*The Canadian Standards Association (CSA) considers combustible gas readings accurate when the displayed values fall between 100% and 120% of the expected value for the gas.

For further instructions on calibration frequency recommendations and a more detailed explanation of accuracy requirements, see Appendix A.

Note: If gas concentration readings do not fall between 90% and 120% (between 100% and 120% to meet the CSA specification) of the expected values during a functional (bump) test, the instrument must be adjusted using the “span” calibration procedures discussed in section 3.4 before further use.

3.3 Fresh air/zero calibration

To initiate the fresh air/zero calibration procedure:

1. From the current gas reading screen, press the MODE button three times within two seconds to begin the fresh air/zero calibration sequence. The Toxi Vision IR CH₄ will briefly display “CAL” and then begin a 5 second countdown.

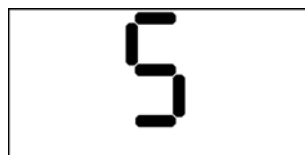

2. Press the MODE button before the end of the 5-second countdown to begin the fresh air/zero calibration. The fresh

air/zero calibration has been successfully initiated when the Toxi Vision IR CH₄ alternates between the following two screens:

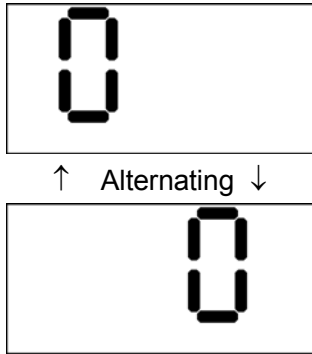

- Once the fresh air/zero calibration is complete, the instrument will begin another 5-second countdown for the span calibration. If span calibration is not required, allow the countdown to reach 0 without pressing the MODE button.

⚠WARNING Fresh air/zero calibrations may only be performed in an atmosphere that is known to be fresh. Fresh air contains 20.9% oxygen, no combustible gases or vapors and no toxic gases. Performing fresh air/zero calibrations in an atmosphere that is not comprised of fresh air may lead to inaccurate and potentially dangerous readings.

3.4 Span Calibration

To perform a span calibration, first perform a fresh air/zero calibration as discussed above in section 3.3. After successful completion of the fresh air/zero calibration, the instrument will begin a second five-second countdown with the calibration gas bottle icon highlighted.

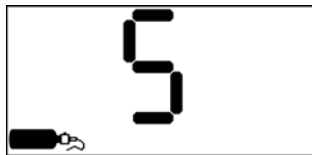

- Press the MODE button before the countdown is complete to initiate the span calibration. The display will alternate between "GAS" and the expected concentration of calibration gas (as shown below in terms of percent LEL).

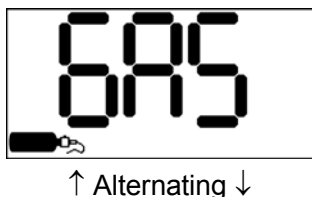

- Apply calibration gas as shown above in figure 3.2. Once calibration gas is detected, the readout will change to show the gas reading.



- The calibration is fully automatic from this point on. Once the instrument successfully completes the span calibration, it will emit three short beeps and display the maximum span calibration value for two seconds.



Note: The max span calibration adjustment value shown is an indication of the relative health of the sensor. As a sensor loses sensitivity, the maximum adjustment level will approach the calibration gas concentration, letting you know when the sensor is losing sensitivity. Once the maximum span adjustment is within 10% of the calibration gas concentration, it is time to order a new sensor.

- The instrument will then turn off.

Note: Once the calibration cycle is completed, the Toxi Vision IR CH₄ automatically returns to normal operation and the gas alarms may be activated. Disconnect the calibration assembly immediately after calibration.

⚠WARNING Use of non-standard calibration gas and/or calibration kit components when calibrating the Toxi Vision IR CH₄ can lead to inaccurate and potentially dangerous readings, and may void the standard Sperian warranty.

3.5 Failure to calibrate

In the event of calibration failure, the "no" and "CAL" screens will be alternately displayed as



shown below before the instrument returns to the gas reading screen.

Fresh air/zero calibration failures often result from the attempt to calibrate the instrument in a contaminated atmosphere. The Toxi Vision IR will show the triangular warning icon along with “no” “CAL” to indicate a failed zero calibration



Following a failed fresh air/zero calibration attempt, the triangular warning icon will appear in the current gas reading screen and the LED will blink until a successful calibration is made.

In the case of a span calibration failure, the “no” and “CAL” screens will be shown with the calibration bottle icon highlighted.



Span calibration failures can be caused by the following:

1. Expired calibration gas.
2. Calibration gas whose concentration fails to match the concentration expected by the instrument.
3. Calibration gas is not methane.
4. Sensor failure.

Following a failed span calibration attempt, the triangular warning icon will appear in the current gas reading screen and the LED and span bottle icon will blink until a successful calibration is made.



3.5.1 Forced fresh air/zero calibration

If a fresh air/zero calibration fails in an atmosphere known to be fresh, the Toxi Vision IR CH₄ can be forced to fresh air calibrate as follows.

1. Follow instructions 1 and 2 in section 3.3 to begin the fresh air/zero calibration sequence.

2. As soon as the alternating right and left 0's are shown on the screen, press and hold the MODE button.



↑ Alternating ↓

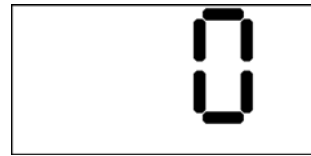

3. The forced fresh air/zero calibration is complete when the instrument emits three short beeps and then moves on the span calibration procedure.

3.6 Fresh air calibration in a contaminated atmosphere

To calibrate the Toxi Vision IR CH₄ in an atmosphere that is known to contain combustible gas, it is necessary to use special calibration gas, whose composition is identical to that of fresh air. Sperian offers the “Zero Air” calibration gas cylinder as part number 54-9039, which contains 0.0% hydrocarbons, 0 PPM toxic gas and 20.9% oxygen.

1. Apply “Zero Air” calibration gas to the instrument as shown above in figure 3.2 for at least 15 seconds or until the readings fully stabilize.
2. Perform the fresh air/zero calibration procedure as described in section 3.3.
3. Once the fresh air/zero calibration is complete, disconnect the calibration assembly and move on to the span calibration if necessary as described in section 3.4.

4. Maintenance

4.1 Replacing alkaline batteries

⚠WARNING Removal or replacement of alkaline batteries in potentially combustible atmospheres may lead to serious injury or death. The alkaline batteries used in the Toxi Vision IR CH₄ may only be removed or replaced in an atmosphere that is known to be free of combustible gas.

⚠WARNING To reduce the risk of explosion, do not mix old or used batteries with new batteries and do not mix batteries from different manufacturers.

To replace the batteries:

1. Remove the six screws on the back of the Toxi Vision IR CH₄.
2. Remove the back cover plate. The two AA alkaline batteries are located near the center of the main board.
3. Remove the old alkaline batteries and install new batteries. Be sure to align the polarity of the batteries as shown on the diagram on the battery compartment.
4. Replace the back cover plate.

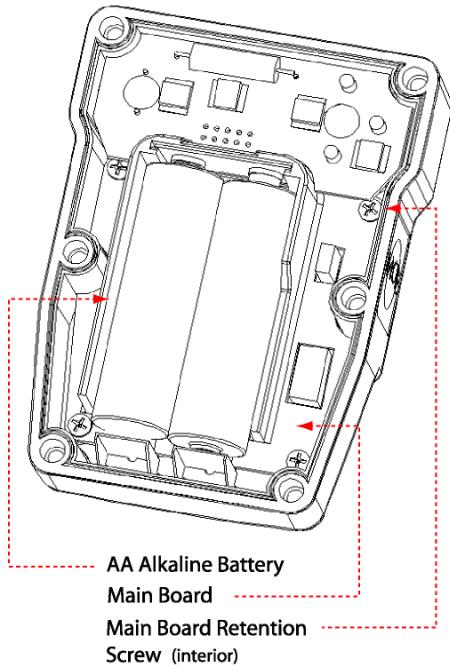

Figure 4.1: Interior view

5. Reinstall the six screws on the back of the instrument that were removed in step 1.

Note: If the calibration due reminder is enabled, the ToxiVision IR must be calibrated following a battery change.

⚠WARNING Use only Duracell MN1500 or Ultra MX1500, Eveready Energizer E91-LR6, or Eveready Energizer EN91 size AA 1.5V alkaline batteries. Substitution of batteries may impair intrinsic safety.

4.2 Charging NiMH batteries

The Nickel Metal Hydride (NiMH) battery contained in the Toxi Vision IR CH₄ is encapsulated in the instrument for safety and may not be accessed by the user.

To charge the batteries, simply plug the Toxi Vision IR CH₄ into a standard electrical socket using the charger that was delivered with the instrument. The Toxi Vision IR CH₄ should charge fully in 12 hours.

The NiMH battery in the Toxi Vision IR CH₄ may not be charged at temperatures lower

than 5 degrees Celsius (40 degrees Fahrenheit) or higher than 38 degrees Celsius (100 degrees Fahrenheit). In the event that charging is attempted outside of the charging range, the instrument will suspend charging and display “too hot” or “too cld” (cold) as appropriate.

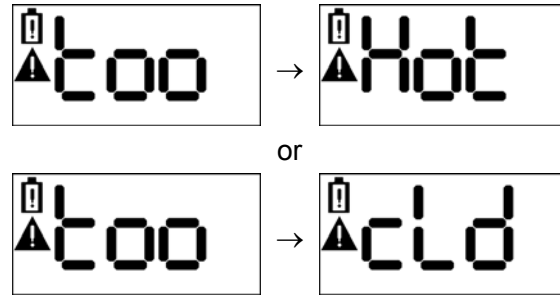

4.3 Replacing sensors

The sensor in the Toxi Vision IR CH₄ may require periodic replacement. To replace the sensor:

1. Loosen the six screws on the back of the Toxi Vision IR CH₄.
2. Remove the back cover.
3. Remove the batteries.

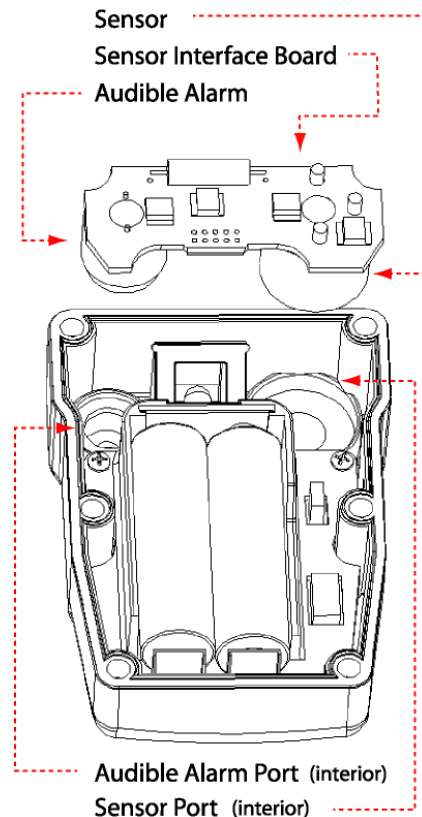

Figure 4.3 Interior view with sensor interface board removed

4. The sensor interface board is located in the top section of the instrument and can be removed by gently pulling it up from the main board.

5. Once the sensor interface board has been removed, gently remove the old sensor and install a new sensor of the same type.
6. Replace the sensor interface board. Be careful to properly align the connector pins, sensor and alarm gaskets before pressing the sensor interface board back into place.
7. Replace the batteries.
8. Replace the back cover.
9. Retighten the six screws on the back of the instrument that were removed in step 1.

Note: The Toxi Vision IR CH₄ must be calibrated after any sensor change. See section 3.3 and 3.4 above for details on the fresh air/zero and span calibration sequences.

5. Direct programming

In the event that an instrument setting needs to be changed in the field and a PC with the appropriate software is not available, the Toxi Vision IR CH₄ can be programmed directly with the MODE button.

⚠WARNING Reprogramming the Toxi Vision IR CH₄ is reserved for authorized personnel. Inappropriate changes made in the Advanced Menu may lead to inaccurate and potentially dangerous readings.

Turn the Toxi Vision IR CH₄ off. Then turn the Toxi Vision IR CH₄ back on, but instead of releasing the MODE button, continue to hold it. The “PC” screen will be shown in approximately 6 seconds.



Continue to hold the MODE button for about 15 additional seconds until the “set” screen is shown, then release the MODE button.

Once dashed lines are shown, immediately click the MODE button three times within three seconds to enter the Configuration Menu. “Set” will be shown.



Click the MODE button once with “ini” shown. After a few seconds, the “ini” screen will be replaced by the “on MAX” or “OFF MAX” screen.



Or



5.1 MAX on or off

With MAX set to on, the maximum reading that the instrument has registered in this operating session can be accessed from the current gas readings screen by pressing the MODE button twice (once to turn on the backlight and once to show the MAX screen). With the MAX setting off, the instrument will not show the max readings during normal operation.

Click the MODE button to change the setting. Once 15 seconds elapse without a change to the setting, the instrument will move on to the LEL or CH₄ setting.



Or

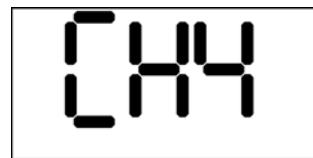

5.2 LEL or CH₄

The default setting for the Toxi Vision IR CH₄ is to show readings in terms of percentage of LEL (Lower Explosive Limit). It may also be configured to read in terms of percent by volume of methane (CH₄).

Click the MODE button to change the setting. The Lower Explosive Limit for CH₄ is 5.0% by volume.

5.0% CH₄ by Volume = 100% LEL

Exploded View Exploded View

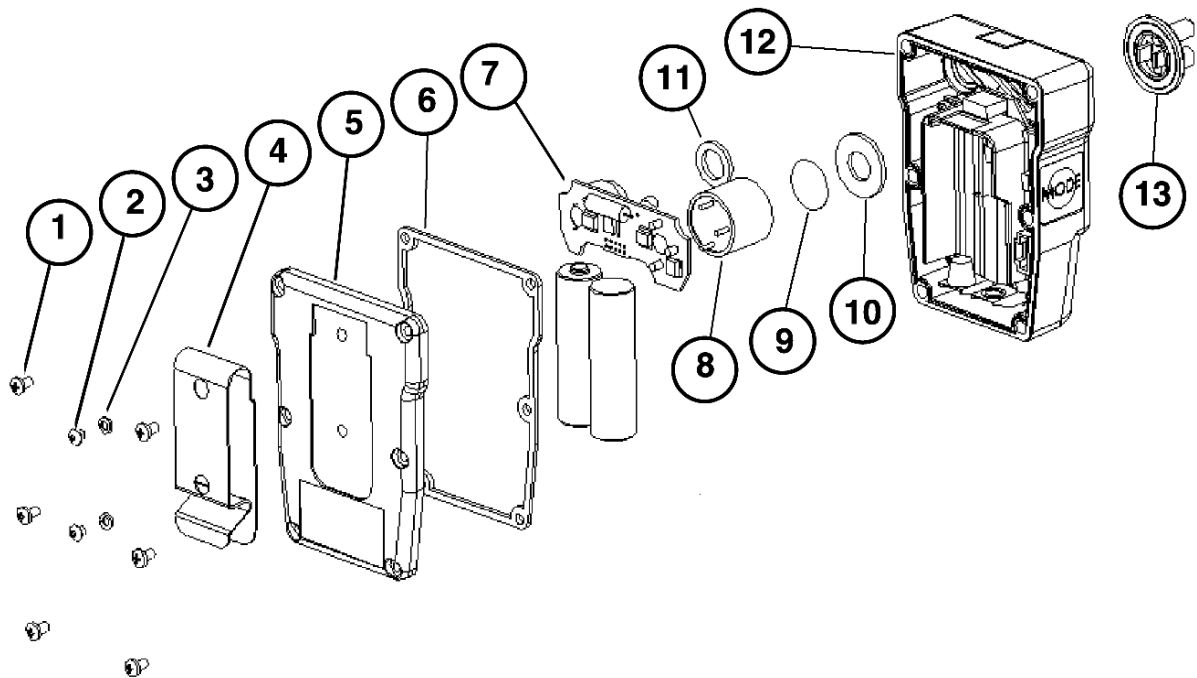

- | | | |
|-----|------------|---|
| 1. | 05-1147(6) | Case retention screws |
| 2. | 05-630(2) | Belt clip retention screws |
| 3. | 05-213(2) | Belt clip retention washers |
| 4. | 55-392(1) | Belt clip |
| 5. | 10-391(1) | Bottom housing |
| 6. | 34-063(1) | Main gasket |
| 7. | ** | Sensor interface board |
| 8. | ** | Sensor |
| 9. | ** | Sensor filter |
| 10. | 34-065(1) | Sensor gasket |
| 11. | 34-066(1) | Alarm gasket |
| 12. | 10-390(1) | Top housing |
| 13. | 54-38-01 | Calibration/sample draw adapter |
| ** | | Sensor interface board, sensor and sensor filter vary with instrument type. |

Appendix A: Calibration Frequency Recommendation

One of the most common questions that we are asked at Sperian Instrumentation is: **“How often should I calibrate my gas detector?”**

Sensor Reliability and Accuracy

Today’s sensors are designed to provide years of reliable service. In fact, many sensors are designed so that with normal use they will only lose 5% of their sensitivity per year or 10% over a two-year period. Given this, it should be possible to use a sensor for up to two full years without any significant loss of sensitivity.

Verification of Accuracy

With so many reasons why a sensor can lose sensitivity and given the fact that dependable sensors can be key to survival in a hazardous environment, frequent verification of sensor performance is paramount.

There is only one sure way to verify that a sensor can respond to the gas for which it is designed. That is to expose it to a known concentration of target gas and compare the reading with the concentration of the gas. This is referred to as a “bump” test. This test is very simple and takes only a few seconds to accomplish. **The safest course of action is to do a “bump” test prior to each day’s use.** It is not necessary to make a calibration adjustment if the readings fall between 90%* and 120% of the expected value. As an example, if a CO sensor is checked using a gas concentration of 50 PPM it is not necessary to perform a calibration unless the readings are either below 45 PPM or above 60 PPM.

Lengthening the Intervals between Verification of Accuracy

We are often asked whether there are any circumstances in which the period between accuracy checks may be lengthened.

Sperian Instrumentation is not the only manufacturer to be asked this question! One of the professional organizations to which Sperian

Instrumentation belongs is the Industrial Safety Equipment Association (ISEA). The “Instrument Products” group of this organization has been very active in developing a protocol to clarify the minimum conditions under which the interval between accuracy checks may be lengthened.

A number of leading gas detection equipment manufacturers have participated in the development of the ISEA guidelines concerning calibration frequency. Sperian Instrumentation procedures closely follow these guidelines.

If your operating procedures do not permit daily checking of the sensors, Sperian Instrumentation recommends the following procedure to establish a safe and prudent accuracy check schedule for your Sperian Instrumentation instruments:

1. During a period of initial use of at least 10 days in the intended atmosphere, check the sensor response daily to be sure there is nothing in the atmosphere that is poisoning the sensor(s). The period of initial use must be of sufficient duration to ensure that the sensors are exposed to all conditions that might have an adverse effect on the sensors.
2. If these tests demonstrate that it is not necessary to make adjustments, the time between checks may be lengthened. The interval between accuracy checking should not exceed 30 days.
3. When the interval has been extended the toxic and combustible gas sensors should be replaced immediately upon warranty expiration. This will minimize the risk of failure during the interval between sensor checks.
4. The history of the instrument response between verifications should be kept. Any conditions, incidents, experiences, or exposure to contaminants that might have an adverse effect on the calibration state of the sensors should trigger immediate re-verification of accuracy before further use.

5. Any changes in the environment in which the instrument is being used, or changes in the work that is being performed, should trigger a resumption of daily checking.
6. If there is any doubt at any time as to the accuracy of the sensors, verify the accuracy of the sensors by exposing them to known concentration test gas before further use.

Gas detectors used for the detection of oxygen deficiencies, flammable gases and vapors, or toxic contaminants must be maintained and operated properly to do the job they were designed to do. Always follow the guidelines provided by the manufacturer for any gas detection equipment you use!

If there is any doubt regarding your gas detector’s accuracy, do an accuracy check! All it takes is a few moments to verify whether or not your instruments are safe to use.

One Button Auto Calibration

While it is only necessary to do a “bump” test to ensure that the sensors are working properly, all current Sperian Instrumentation gas detectors offer a one button auto calibration feature. This feature allows you to calibrate a Sperian Instrumentation gas detector in about the same time as it takes to complete a “bump” test. The use of automatic bump test and calibration stations can further simplify the tasks, while automatically maintaining records.

**Don’t take a chance
with your life.
Verify accuracy frequently!**

Please read also Sperian Instrumentation’s applications note: AN20010808 “Use of ‘equivalent’ calibration gas mixtures”. This application note provides procedures to ensure safe calibration of LEL sensors that are subject to silicone poisoning.

The Sperian Protection Instrumentation, LLC website is located at <http://www.biosystems.com>

Toxi Vision IR CH₄

Software Version _____

Vibrating Motor

Datalogging

Serial Number _____

MFG Date _____

Sperian Instrumentation Toxi Vision IR CH₄ Standard Warranty

General

Sperian Protection Instrumentation, LLC (hereafter Sperian) warrants gas detectors, sensors and accessories manufactured and sold by Sperian, to be free from defects in materials and workmanship for the periods listed in the tables below.

Damages to any Sperian products that result from abuse, alteration, power fluctuations including surges and lightning strikes, incorrect voltage settings, incorrect batteries, or repair procedures not made in accordance with the Instrument's Reference Manual are not covered by the Sperian standard warranty.

The obligation of Sperian under this warranty is limited to the repair or replacement of components deemed by the Sperian Instrument Service Department to have been defective under the scope of this standard warranty. To receive consideration for warranty repair or replacement procedures, products must be returned with transportation and shipping charges prepaid to Sperian at its manufacturing location in Middletown, Connecticut, or to a Sperian Authorized Warranty Service Center. It is necessary to obtain a return authorization number from Sperian prior to shipment.

THIS WARRANTY IS EXPRESSLY IN LIEU OF ANY AND ALL OTHER WARRANTIES AND REPRESENTATIONS, EXPRESS OR IMPLIED, INCLUDING BUT NOT LIMITED TO, THE WARRANTY OF FITNESS FOR A PARTICULAR PURPOSE. SPERIAN WILL NOT BE LIABLE FOR LOSS OR DAMAGE OF ANY KIND CONNECTED TO THE USE OF ITS PRODUCTS OR FAILURE OF ITS PRODUCTS TO FUNCTION OR OPERATE PROPERLY.

Instrument & Accessory Warranty Periods

Product(s)	Warranty Period
ToxiVision IR CH ₄	As long as the instrument is in service
Battery packs and chargers, sampling pumps and other components, which by their design are consumed or depleted during normal operation, or which may require periodic replacement	One year from the date of purchase

Sensor Warranty Periods

Instrument(s)	Sensor Type(s)	Warranty Period
ToxiVision IR CH ₄	IR	1 Year